

2020 World GreenMech Contest Regulations

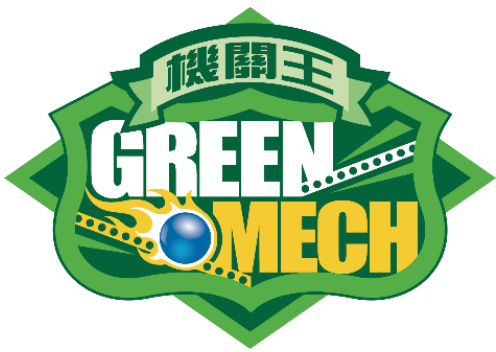

Hosts: -King Mongkut's University of
Technology North Bangkok
-Suansunandha Rajabhat
University
-World Forum For GreenMech
Promotion

Co-Organizers: Genius Toy Taiwan Co., Ltd
PADA EDUCATION

World GreenMech Official Website: www.worldgreenmech.com

Contact: Ms. Wu
conniewu@mail.gigo.com.tw

Contents

1. Contest Purpose	3
1. 1. Notes on the Regulations:	3
2. General Contest Information.....	4
2. 1. Summary of Events.....	4
2. 2. Player Replacement	4
2. 3. Cross-group registration is prohibited	4
2. 4. Enrollment & Qualification	5
2. 5. Event Schedule.....	5
2. 6. Registration Deadlines	5
3. Notes for Applicants	6
3. 1. Registration Information.....	6
3. 2. Team Names	6
3. 3. Registration Fee	6
3. 4. Up-to-date Information	6
4. Venue Regulations	7
4. 1. Identity Check.....	7
4. 2. Access Restrictions	7
4. 3. Causing Unwanted Disturbances	7
4. 4. On-site Facilities	7
4. 5. Communications & Communication Devices	7
4. 6. Theft or Sabotage.....	7
4. 7. Permitted Materials.....	8
4. 8. Video Records for Evidence	8
4. 9. Dispute Handling	8
5. Awards	9
5. 1. World GreenMech Awards- GM & R4M Contest Award.....	9
5. 2. GreenMech Junior Contest Award.....	9
5. 3. Award Revision	10
5. 4. Award Distribution	10
5. 5. Competition Certificates	10
5. 6. Awards Delivered by Mail.....	10

5. 7. Winning Team Obligations.....	11
6. Legal Policy	12
6. 1. Contestant Insurance	12
6. 2. Intellectual Property Rights	12
6. 3. Organizer’s IPR	12
7. GreenMech (GM) Contest	13
7. 1. Theme & Purpose: Industry 4.0.....	13
7. 2. Event Schedule.....	13
7. 3. Work Specification	15
7. 4. Scoring	17
7. 5. Appendix.....	37
8. Robot for Mission (R4M)	40
8. 1. Contest Theme: Smart Farm	40
8. 2. Project Requirements & Restrictions.....	42
8.3. Contest Instructions	45
8.4. Scenario.....	45
8. 5. Scoring Criteria.....	58
8.6. Contest Site Rules	60
9. GreenMech Junior Contest	62
9. 1. Theme: Competition One: Inertia Flywheel 2.0, Competition Two: Sharpshooter.....	62
9. 2.Event Schedule.....	62
9. 3. Contest Objectives	63
9. 4. Contest Method.....	64
9. 5. Criteria	69
10. Appendix & Forms	70
10. 1. List of Race Contest Motor Models.....	70
10. 2. Student Enrollment Certificate	73
10. 3. Complaint Form	74

World GreenMech Contest Regulations

1. Contest Purpose

The 2020 World GreenMech Contest is an engineering-for-fun challenge, run by the World Forum for GreenMech Promotion. Using scientific principles, this competition combines Science, Technology, Engineering, Art, and Mathematics (STEAM) to promote learning and growing. There are three contests: (i) GreenMech (ii) R4M and (iii) GreenMech Jr. Each seeks to inspire contestants in their own way to engage in scientific study, creative problem solving, and better understand the use of scarce resources when project planning. Contestants can enjoy pitting their different skills, abilities and creativity against each other in a fun and friendly environment. There is ample opportunity for all contestants to make their contribution count.

1. 1. Notes on the Regulations:

“Organizer” refers to the GreenMech (hereafter GM) and the Robot for Mission (hereafter R4M) competition Organizers.

All times and dates use the standard US system, mm/dd/yyyy and the 24-hour clock.

2. General Contest Information

2. 1. Summary of Events

2020 World GreenMech Contest				
	GreenMech	R4M	GMJr.	Remarks
Participant Selection	Full time students in grades 1-12.	Full time students in grades 1-12.	1. Kindergarten and Full-time students in grades 1 2. Full-time students in grades 2- 4. (Born between Sep 1, 2009 and Aug 31, 2014) This year the contestants are divided into two levels.	Students in education until May 30, 2020
Team Size	3 to 4 people	3 to 4 people	1 to 2 people.	For rules governing replacement of team-mates see in section 2.2
No. of Instructors	1 to 3 people	1 to 3 people	1 person.	The instructor can be a teacher or parent

2. 2. Player Replacement

If a player should be unexpectedly absent from the contest for any reason, the team leader can apply for replacements, subject to a per team limit of 50% of the original number of applicants. Application for a replacement must be prior to July 19th 2020.

2. 3. Cross-group registration is prohibited

In order to avoid disputes, cross-group registration is prohibited. If students are unable to present their student registration certificate on arrival at the competition venue, a photograph will be required for confirmation of identity. If a contestant has broken the rules they will be disqualified and any prizes/certificates will be revoked.

2. 4. Enrollment & Qualification

Notes	All countries
Enrollment through countries is strongly recommended.	Local and national organizers for each country and region will be responsible for their region.

2. 5. Event Schedule

	Online Registration Date	Admission Announcements	Contest Date	Contest Location	Remarks
2020 GM World Contest	06/08/2020 – 06/12/2020	06/16/2020	08/06/2020	Pattaya, Thailand	<u>http://www.nongnoochtropicalgarden.com/th/meeting/ศูนย์ปรีชาภรณ์นานาชาติ/</u>

2. 6. Registration Deadlines

Registration for the World GreenMech a Contest must be completed within the time limits specified by online registration, there will be no flexibility in this regard. Deadlines remain the same for independent applications and regional qualifying.

3. Notes for Applicants

3. 1. Registration Information

Participation must be completed within the time limits specified for online registration (06/08/2020 – 06/12/2020). More information can be found at the WGM official website: www.worldgreenmech.com.

3. 2. Team Names

Teams must use English as the team name. If the name is duplicated, the name will be granted on a first come, first served basis. The second applicant will be required to choose a different team name. The English team name is limited to 30 letters (including spaces) and there must be no indecency or innuendo. The Organizer has the right to ask teams to change their names.

3. 3. Registration Fee

(1) GM, R4M: Teams must pay a USD \$100 (NTD \$3000) registration fee. This is not a returnable deposit and can be paid online during registration.

(2) GMJr.: Teams must pay a USD \$50 (NTD \$1500) registration fee. This is not a returnable deposit and can be paid online during registration. Each team will receive a set of Gigo #1261 Scientific Tour. Individual contestants each receive a T-shirt, a set of Gigo #T200 Lucky Rat and a commemorative medal. Instructors will receive one set of Gigo #T200 Lucky Rat.

3. 4. Up-to-date Information

For up to date information and announcements, please check the event website regularly. Contestants are expected to take personal responsibility in this regard.

4. Venue Regulations

4. 1. Identity Check

Please fill in the Certificate of Student Enrollment shown in 0Submit appropriate identity documents at the time of the contest. If the required information is not received, contestants will need to be photographed for future reference. If a contestant's identity is in question, proof of identity must be submitted. If the student cannot supply the required proof, they will be disqualified.

4. 2. Access Restrictions

During the contest, team leaders or parents are not allowed to enter the contest area or pass anything to the contestants. Any violations will result in a 5-point deduction from the team score.

4. 3. Causing Unwanted Disturbances

During the contest, no person or team can disturb the work of other persons, teams or judges in any way. This includes running around or making loud noises. If this rule is violated and a warning has already been given, violators will receive a 5-point deduction.

4. 4. On-site Facilities

This contest only provides the contestants with display tables. Each GM and R4M team have one whole table, GMJr. teams share one table between two teams. Competing teams can bring their own chairs if required. Any additional furniture should not obstruct main pathways or exits.

4. 5. Communications & Communication Devices

During the contest, contestants shall not speak to or exchange information with any non-contestant. This ban includes team leaders or parents, and all means of communication including phones or written notes. Upon confirming such communication has taken place, an offending team will suffer a 5-point deduction from their score. In the event of distress, contestants should contact event services for help.

4. 6. Theft or Sabotage

In the highly unlikely event of any theft, between group sabotage, robbery or fraudulent seeking of another's possessions, event Organizers will first verify the claim. If the claim is verified, the offending team will receive a 5-point deduction as a minimum punishment.

4. 7. Permitted Materials

Contestants can carry written materials, pictures, video file and other printed data into the contest area.

4. 8. Video Records for Evidence

To avoid any unwanted controversy after the contest, each contesting team should cooperate with the Organizer to record their project in operation for future reference.

4. 9. Dispute Handling

Contestants should always respect the final decision of the Organizer. If there is any doubt about a decision during production or appraisal, the contestants should object to the assessment immediately. If a consensus cannot be reached, the staff present will take contestants to the information counter to fill out an official complaint (see section 0) and then invite the chief judge to make a final ruling. Contestants shall sign and confirm details regarding the complaint after chief judge has explained the outcome of the appeal. After the contest, no further objections can be raised or heard.

5. Awards

5. 1. World GreenMech Awards- GM & R4M Contest Award

Position	Prizes	Number of Awards
Gold Medal (1 st place)	<ol style="list-style-type: none"> 1. Award certificate for contestants and the team leaders. 2. Cash USD \$ 660 3. One Princess Cup Trophy 	One team for each division
Silver Medal (2 nd place)	<ol style="list-style-type: none"> 1. Award certificate for contestants and team leaders. 2. Cash USD \$ 330 	Two teams for each division
Bronze Medal (3 rd place)	<ol style="list-style-type: none"> 1. Award Certificate for Contestant and team leaders 2. Cash NTD USD \$ 160 	Three teams for each division
Honorable Mention Award	Award certificate for contestants and team leaders.	For top 50 th percentile in each division
STEAM Overseas Educational Contribution Award	Award certificate for contestants and team leaders.	For overseas countries

5. 2. GreenMech Junior Contest Award

Position	Prizes	Number of Awards
Gold Medal	<ol style="list-style-type: none"> 1. Award certificates for contestants and team leaders. 2. One product prize for each participant. 3. One Princess Cup Trophy 	One team for each division

Silver Medal	1. Award certificates for contestants and team leaders. 2. One product prize for each participant.	One teams for each division
Bronze Medal	1. Award Certificates for contestants and team leaders. 2. One product prize for each participant.	One teams for each division
Honorable Award	Award certificates for contestants and team leaders.	For top 50 th percentile in each division.
STEAM Overseas Educational Contribution Award	For overseas countries	

5. 3. Award Revision

The Contest Organizers hold the right to adjust the above prize schedules for any reason, which may mean increasing or decreasing them. The total number of teams entered in the competition may be a factor in deciding final prizes if the number of contestants' changes.

5. 4. Award Distribution

The Gold Medal, Silver Medal, Bronze Medal winners will be announced on the day of the contest. All certificates will be sent to the first named person listed on the registration document. Certificates will be sent after the contest and can be expected to arrive within one month of the award ceremony.

5. 5. Competition Certificates

All contestants will be presented with digital certificates as a gesture of encouragement. These certificates will be downloadable by contestants and team leaders after the contest, and can be printed by participants.

5. 6. Awards Delivered by Mail

Merit certificates for winning teams will be sent out within one month of the completed contest. Please pay attention to official website announcements. Winning teams that have not received awards should contact the Organizer for replacements. In the event of incorrect

personal information being submitted during registration (i.e. wrong name, mail or email address) postage and other costs for replacement will be borne by the contestant for USD\$7.

5. 7. Winning Team Obligations

Winning teams must cooperate with the Organizer to display and preserve their works. The Gold Medal and the Silver Medal winners of the world-series are required to provide their model for filming within one month of the competition, to facilitate promotion and further education. If it is preferred, contestants can film their model in operation before the contest.

6. Legal Policy

6. 1. Contestant Insurance

The Organizer shall buy group insurance for all the contestants. This covers the day of the contest only. The contestants and the team leaders shall fill out their correct personal information in the Registration Information Form online. Without this, the Organizer will not be able to buy group insurance and cannot be held liable for payment of any damages.

6. 2. Intellectual Property Rights

During the online registration, team leaders must sign to confirm the contestants' original production statement and to ensure their works do not infringe on known patent or intellectual property rights of others. If the contestants need to use another person's IPR, they must submit a letter of authorization from the copyright owner at the time of registration to prove legitimate use.

6. 3. Organizer's IPR

All competing teams shall grant their project's IPR to the Organizer, who for the need of publicity, is entitled to revision, photography, publishing, book-compilation, exhibition, production and plate display of the created works, with no objection from the winners. In case the Organizer needs to carry out derivative designs of the award-winning work, the winners should cooperate in supplying pictures and the documents.

7. GreenMech (GM) Contest

7. 1. Theme & Purpose: Industry 4.0

Industry 4.0 is the use of automation, sensors, Internet of Things (IoT), supply chain management, internet, big data, and human-machine collaboration to improve people's lives. It is revolutionizing productivity and quality across all forms of manufacturing and commerce. With advancements in science and technology and smart manufacturing Industry 4.0 is becoming a complete "smart industry" chain. It is hoped that it will improve all areas of life by decreasing labor and increasing productivity.

7. 2. Event Schedule

GreenMech Schedule		
Time	Item	Remarks
07:40 - 08:20	Registration	<p>(i) Enter the venue and find your team table. Place all contest materials under the table in an orderly manner. Contestants can begin to assemble Jumbo Base Grids (60 x 180 cm) on the table.</p> <p>(ii) Only contestants may be in the competition area after 08:00. Team leaders and parents/guardians are not permitted after this time.</p>
08:00 - 08:50	Materials & Registration Check	<p>(i) Team leaders shall not enter the competition venue after 08:00.</p> <p>(ii) Judges will carry out a building materials inspection. Except for the chain, no blocks may be assembled in advance.</p> <p>(iii) After a brief inspection, teams will be given a "qualified" label, whereupon contestants should remain at the table and should not touch the materials.</p> <p>(iv) Personal items can be brought into the venue but must be placed on the table in conjunction with the inspection records.</p>

		(v) Contestants must present their Certificate of Student Enrollment at this time, see section 10.2 for more information.
08:50 - 09:00	Opening Ceremony/ Clarification of Rules	
09:00 - 11:40	Production & Testing	<p>(i) Please observe all competition rules.</p> <p>(ii) When leaving, do not run, be careful not to touch another group's work.</p> <p>(iii) There will be 160 minutes between commencement and lunch (12:00) when contestants will be able to leave the venue.</p> <p>(iv) Contestants must remember to organize the venue and keep their space tidy. Personal items can be stored under the tables.</p> <p>(v) By 11:00 the Scientific Principles reference table will be collected by the Organizer.</p>
11:40 - 12:30	Lunch	Everyone is personally responsible for sorting refuse and recycling correctly.
12:30 - 12:40	Announcements	Contestants should wait for the Organizer's announcements and be prepared to continue. If contestants are not present at this time, they may not continue with the competition.
12:40 - 12:50	Fine-tuning	Wait for the Organizer's instruction to begin.
12:50 - 16:30	Appraisals	Please refer to section 7.4
16:30 - 17:00	Feedback & Communications	Parents, teachers and peers may enter and discuss the projects.
17:00	Award Ceremony	Organizers make every effort to finish on time, but patience may be required depending on announcements and other possible delays.

7.3. Work Specification

7.3.1 Dimensions

All work must be constructed on a table 180cm long and 60cm wide. A virtual rectangular space shown in Figure 1 extends upwards for 100cm. Work is not limited in height, but projects may only extend outward beyond the horizontal boundaries above 100cm. Projects extending must be safe and steady. If the constructions do not meet these requirements and have not been modified after a warning, 5 points will be deducted.

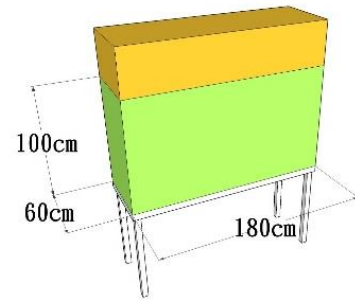

Figure 1. Green shows the allowable building area. Within the green area (60 x 100 x 180 cm) no penalty is applied. If the model exceeds the horizontal limits below 100 cm, a 5 point deduction will be applied. Models may exceed the horizontal space limit, but only above 100 cm, and where it is safe and stable.

7.3.2 Material Specifications

Teams must carry any unassembled GreenMech parts themselves. All parts are certified non-toxic to state-level thresholds, CE (European), ASTM (US), ST (Taiwan), and CCC (China). Any uncertified materials brought in to the contest may lead to a point penalty or disqualification. Lost, broken, or damaged parts cannot be replaced.

7.3.3 Additional Materials

- i. Teams may carry un-processed materials and recycled materials such as cardboard, wood, cans, and bottles to augment their projects.
- ii. Remote or programming control is not permitted for devices and only the specified device area(s) can use programming control devices. Violation of this rule will result in a 5-point penalty.
- iii. All electronic products including mobile phones, tablets, laptops, etc., are not recommended for use in projects. Teams using such devices will not be granted any bonus for including them. This contest allows the use of 3D printed parts and laser-cut parts. Each piece must not exceed 4cm x 4cm x 4cm and no components may be assembled in advance. Violation of this rule will result in a 5-point penalty.

7.3.4 Safety of Materials

Dangerous materials are strictly prohibited. Anything flammable, corrosive, electronically dangerous, or biologically discomfiting will be sufficient cause for disqualification.

7.3.5 Power Source Regulations

There is no power supply available in the contest venue for safety reasons. All contestants need to bring their own batteries. Battery voltages must 5V or less. Multiple batteries in

series must be 15V or less, for safety reasons. Any violation in this regard will result in a 5-point deduction from the team score. The competition prohibits the use of lead batteries, uninterruptible power systems (UPS) or other large, potentially dangerous batteries. Violation of this rule will result in a 5-point penalty. If bodily injury should occur as a result of this rule breach, the team shall be immediately disqualified and expected to make recompense for the situation.

7. 4. Scoring

7.4.1 Criteria

Scoring	Weighting	Standards
Total Number of Devices	9%	<ul style="list-style-type: none"> (i) The number of devices is calculated by the main path of the projects. Branch devices are not included in the scoring process. Teams must clearly specify the first and last stages as well as the order of operations. (ii) The project should contain 7 regular devices, 2 green energy source devices, and 1 specified device. (iii) The device number assigned only applies to the device itself, not to any specified objective. 1 point will be given for correctly tagging each device and 0 point for unlabeled devices. See section 7.5.2 for device labels.
Scientific Principle Applications	14%	<ul style="list-style-type: none"> (i) The application of scientific concepts includes scientific principles, laws, phenomena and structures as set out in section 7. 5. .1 (ii) Each device must prove 2 scientific concepts. Scientific concepts (1 action counts as a scientific concept) should not be duplicated between devices. A total of 14 scientific concepts, each earning contestants 1 point each can yield a maximum of 14 points. (iii) At the time of examination, the empty list of scientific concepts will be released. Contestants should refer to the list as their work to ensure they are fulfilling the required objectives. At 11:00, the Scientific Principles Reference Table will be collected by the

		<p>Organizer. Submission of an incomplete table will not score points.</p> <p>(iv) If there are more than two scientific concept designs for a device, contestants should tick only two scientific concepts to be presented for that device. Only 14 scientific concepts can be checked on the self-assessment form, with no score exceeding 2 points per device. Please refer to section 7.4.5 for more information.</p>
Green Energy Source Applications	10%	<p>(i) There are five kinds of green energy sources: wind, hydro, solar, magnetic and chemical. Teams earn 3 points for compliance with green energy specifications. Each green energy-driven device that successfully completes its objective will earn 2 points.</p> <p>(ii) Green energy devices can only be used after the first device and before the specified tasks. Green energy applications may not be repeated or combined with regular devices. The highest score available from this part is 10 points.</p> <p>(iii) Green energy devices must be labeled using the labels in Section 7.5.2.</p> <p>(iv) There is only one opportunity to complete the task.</p> <p>(v) If a team uses green energy sources for the first device, they will not be awarded any green energy score. For more information on Green energy use, refer to section 7.4.6.</p>
Smoothness	20%	<p>(i) The smoothness score is based on the operation of the 7 general devices, 2 green energy devices, and how well the specified task are completed, from beginning to the end.</p>

		<p>(ii) Contestants should be able to brief judges on the objectives they have completed for all devices including green energy. Contestants should be prepared to discuss the scientific concepts, green energy design and the scientific principles of any devices they have, and explain how they fulfill the requirement of the device.</p> <p>(iii) When the device is in operation, 2 points will be deducted if anything falls out of the device (60cm x 180cm). If several objects fall together at one time, points will only be deducted once. If the same item falls multiple times, points will be deducted multiple times.</p> <p>(iv) No points will be deducted if powder or liquid are dropped, within reason. Contestants should remember, however, that negatively affecting the cleanliness of the contest area may be cause for point deduction.</p> <p>(v) If there is a problem with the functioning of a device after it has been put in the arena and it requires manual intervention to resume operation, the team will receive a 2-point deduction.</p> <p>(vi) If a scientific principle or green energy application fails in a device, but overall operation continues, the manual intervention penalty is applied.</p> <p>(vii) The Smoothness score includes 7 regulars devices, 2 green energy devices, and the action to activate the feeding mechanism of specified tasks.</p>
--	--	---

		<p>(viii) The smoothness score will be multiplied by the score for devices used, e.g. if the score from the number of working devices is 7 points, with one manual intervention, and one ball drop, the Smoothness score will be calculated as:</p> $(20 - 2 - 2) \times 7/9 = 12.44 \text{ points.}$
Creativity	15%	<p>For 3 creativity tasks in design (9 points) and the overall design concept of the work (6 points).</p> <p>(i) Creativity points are awarded in two categories, structure, and creativity of appearance. Up to 3 points can be awarded for each device in each category.</p> <p>(ii) Two creative devices must be included between devices 1 – 7, the third creative device will be graded for the drying device in specified device area B and the whole of Specified device. Points are awarded for device structure. Up to 3 points can be awarded for each device.</p> <p>(iii) Points for describe performance of the device and overall design aesthetics, uniqueness, structure and program complexity are awarded separately, making a total of 6 points for each device.</p>
Specified Tasks	32%	Please refer to 7.4.4.
Rule violations	On-site points deduction	<p>The following situations are a violation of the rules:</p> <p>(i) Programming can only be used for automatic control devices at specified devices. Devices 1 -7 and Green Energy cannot use programming or remote control. Violations of this rule will result in a 5-point deduction.</p>

		<p>(ii) Size violations will result in a 5-point deduction.</p> <p>(iii) Untidy work areas or poor “housekeeping” (e.g.: unruly scattered materials, wet and slippery floor), with no improvement after warning, will result in a 5-point deduction.</p> <p>(iv) Failure to observe the contest rules, disturb the project work of others, with no correction after a yellow card warning, shall result in a 5-point deduction. Repeated severe infractions will lead to disqualification.</p> <p>(v) Violation of power usage regulations shall result in a 5-point deduction.</p> <p>(vi) Violation of regulations governing 3D printing parts and laser cutting parts will result in a 5-point deduction.</p>
--	--	--

7.4.2 Work Configuration Chart

Green energy sources may be used between devices on the way to the specified devices. They cannot be used in the first device.

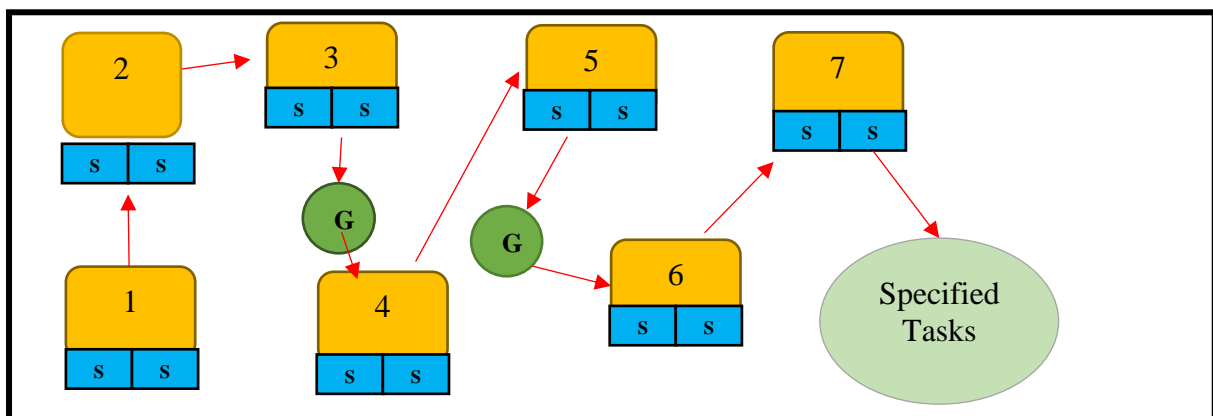

Figure 2. Work configuration chart showing devices and labels.

7.4.3 Grading Method

Grading preparation	<p>(i) During the grading time, contestants should sit near their work. Contestants should not frolic or run around. If behavior does not improve after a warning, 5 points will be deducted. Before grading, please cooperate patiently with staff instructions.</p> <p>(ii) During grading, contestants are required to stand in the specified position according to staff instructions and should not touch the work unless instructed.</p>	
Criteria for Grading	Total number of devices	<p>(i) Show the main operation path for the devices and confirm that green energy source and device labels (1 to 7) are displayed clearly.</p> <p>(ii) Contestants should sign to say they have received a score after grading.</p>
	Scientific principle applications	<p>(i) Contestants should give a briefing on the operation of their device in the order of operation.</p> <p>(ii) Judges must be explained the effects and scientific concepts involved with each device.</p> <p>(iii) Contestants should sign to say they have received their score after grading.</p>
	Green energy source applications	<p>(i) Contestants should make sure that their labels are properly affixed.</p> <p>(ii) Green energy applications are allowed between device 1 and the specified device only.</p> <p>(iii) Contestants need to describe in detail, the operation and process of green energy use before proceeding.</p> <p>(iv) Judges have the right to require the effects of green energy operation for scoring.</p> <p>(v) Contestants should sign to say they have received their score after grading.</p>
	Smoothness	<p>(i) Contestants should introduce the operation and science concepts for their devices.</p>

		<ul style="list-style-type: none"> (ii) Main-line devices and branch devices are included in the score. (iii) If anything falls or needs to be manually operated during operation, contestants must wait for the judge’s permission to intervene. (iv) There is only one opportunity to complete the task and the score must be multiplied by the number of devices. (v) Contestants should sign to say they have received their scores after grading.
	Specified Tasks	<ul style="list-style-type: none"> (i) Contestants should be able to give judges an introduction to the operation of their devices. (ii) Teams start their device introduction from device 7 and complete one full cycle. (iii) There is only one opportunity to complete the task. (vi) Contestants should sign to say they have received their score after grading.
	Creativity	<ul style="list-style-type: none"> (i) Describe the concept behind the design or theme. (ii) This contest is graded by a number of judges; it does not require a contestant’s signature.
Grade Groups	After the number of enrolled teams is confirmed, the criteria for grading and grading times will be announced on the official website one week before the competition, contestants are responsible for being aware of this information.	

7.4.4 Specific Requirements - Industry 4.0

7. 4. 4.1 Specified Devices Process

Industry 4.0 Production Line						
1	2	3	4	5	6	7
Preparation Platform	Material Feeding Device	Conveyor Device	Counting	Static Removal Platform	Drying Device	Operation Warning Light
A	A	A-B		B	B	B

Industry 4.0 Production Process			
8	9	10	11
Self-regulating Feeder	Material Dispenser	Mechanical arm	Cargo Collection Box
B-C	C	C-D	D

- a. Elementary School - Specific Requirements:
Processes 1 through 7 need to be built so that materials in zone A are individually transferred to zone B in sequence. Areas outside of Process 1 to Process 7 can be placed with regular or green energy devices.
- b. Junior High School - Specific Requirements:
Processes 1 through 9 need to be built so that materials in zone A are individually transferred to zone B, then to zone C, in sequence. Areas outside of Process 1 to Process 9 can be placed with regular or green energy devices.
- c. Senior High School - Specific Requirements:
Processes 1 through 11 need to be built so that materials in zone A are individually transferred to zone B, then to zone C, in sequence. There must also be a set of mechanical arms that can automatically classify materials in zone C and put them in zone D.

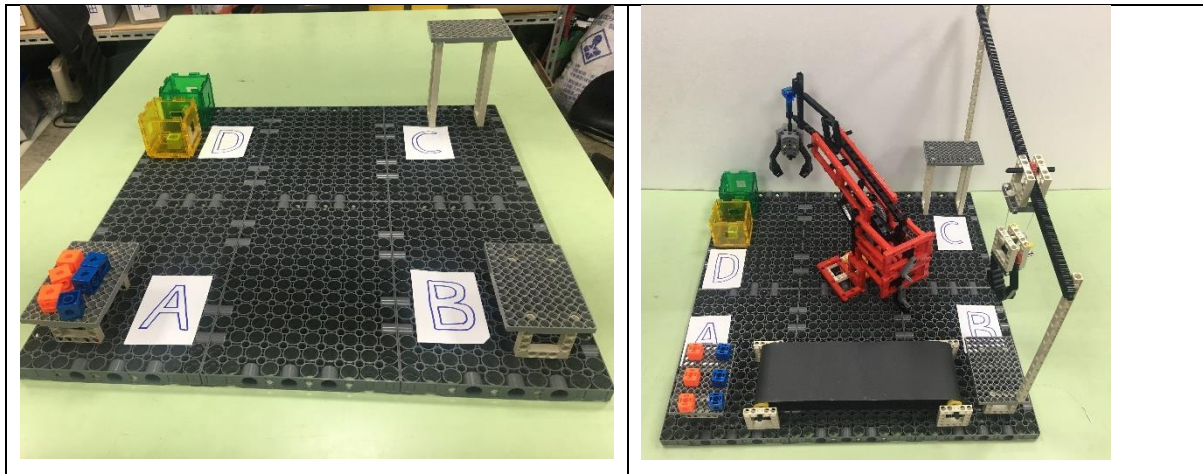

7.4.4.2 Task: (30 points)

Area	Criteria
Zone A	<p>(i) In zone A, use one BASE GRID (8 x 12cm) and two ARCH FRAMES (5 x 5cm) to make a platform for “production materials”. The platform can be placed anywhere in zone A, but its outermost edge must be within the zone as shown on Page 31.</p> <p>(ii) Use Gigo blocks to make a device to feed materials into the production process (“Automatic Feeding Device”). There is no size restriction and it can extend into zone A. Use Gigo blocks (880-W10-N1G) as “production materials” in two colors (6 in total), that can be individually placed on the conveyor in sequence.</p> <p>(iii) Three yellow and three green production materials are placed by contestants, but must be completely completed on the table within zone A.</p>
Between Zones A & B	<p>(i) Use blocks to make a conveyor device which can individual sequentially transfer production materials to the Static Removal Platform in zone B.</p> <p>(ii) Only the conveyor may use non-Gigo blocks, expect of paper and plastic. It is allowed to use adhesive tape, foam rubber, etc. to glue the surface of the conveyor .</p>

	(iii) Teams must create a counting near the conveyor that can count materials and display the number of materials used, in sequence from 1 – 6.
Zone B	<p>(i) Within the zone B, use one 8x12cm BASE GRID and two 5x15 ARCH FRAMEs to make the Static Removal Platform. The platform can be placed anywhere in zone B, but its outermost edge must be within the zone as shown on Page 31.</p> <p>(ii) Design a drying device and put a warning light on the static removal platform. When the material is placed on the platform, the warning light will light up. When there is no raw material on the platform, the warning light will be off.</p> <p>(iii) The location of the six building materials shall be completely within the 8x12cm BASE GRID , and shall be lower than the material dispenser in zone C.</p> <p>(iv) Use Gigo blocks to make a mechanism that represents a drying device. This device will be graded according to creativity and complexity of its design. It is not restricted in size, and can exceed zone B.</p>
Between B, C Zone	(i) Use Gigo blocks to make an automatic material feeder that can transport materials from the static removal platform to the material dispenser (from low platform to high platform). Teams may use rubber bands to increase the grip of the device.
Zone C	<p>(i) Within zone C, use one 8x12cm BASE GRID and two 5x15cm ARCH FRAMEs to make a material dispenser. The position of this platform is up to the contestants, but its outermost edge must be within the zone as shown on Page 31.</p> <p>(ii) The six building materials must remain completely within the 8x12cm BASE GRID.</p>
Between C, D Zone	(iii) Use Gigo blocks to make a set of mechanical arms (teams can use rubber bands to increase the grip of the device) to automatically transfer materials from zone C to zone D. Materials must be sorted and put in the correct cargo collection box. The mechanical arm

	<p>structure must include an arm, a motor, a control board and a sensor.</p> <p>(iv) The device should automatically sort and box materials coming from the material dispenser in zone C. The two-colored materials must be sorted into their respective boxes.</p> <p>(Scoring is primarily based on correct sorting of the materials by their color. Either color can go in either box, but both the colors must be separated.)</p>
<p>D Zone</p>	<p>(i) Two cargo collection boxes are represented by D SQUARES. The position of the cargo collection boxes is up to the team, but its outermost edge must be within the zone as shown on Page 31. The yellow and green materials are placed in two sets of cargo boxes. The box with more materials is defined as box A. The more colors in box A are defined as color A. Those who match the correct color receive 10 points, and those who do not receive the correct color receive 5 points. Minute.</p> <p>(1) Box A (3A); Box B (3B), you can get $30 + 30 = 60$ points</p> <p>(2) Box A (3A1B); Box B (2B), you can get $35 + 20 = 55$ points</p> <p>(3) Box A (2A); Box B (1A1B), you can get $20 + 15 = 35$ points</p>
<p>Rule violations (For Specified device ONLY)</p>	<p>(i) All devices must be assembled using Gigo blocks (including Gigo motors or Gigo servo motors). Do not use materials other than blocks and in other words, only Specified device can be in the orthographic projection area above it.</p> <p>(ii) The conveyor can be made from non-Gigo materials such as paper, plastic, and sticky materials such as tape, or glue. Screws and straps can be used.</p> <p>(iii) Rubber bands, cotton, string and magnets can be used in devices.</p> <p>(iv) All parts from the Gigo catalogue (including decorative cardboard) can be regarded as using Gigo blocks, but they must be assembled in such a way that they do not require glue.</p> <p>(v) It's allowed to use circuit control in Specified device. The program control section can use various types of control board,</p>

- such as Arduino or micro: bit, but it must be assembled and secured using blocks, not fixed with glue.
- (vi) Commercially available sensors, switches, warning lights, wires and other circuit components are permitted. They must be fixed using blocks, and must not be glued.
 - (vii) When materials are delivered, these materials must pass over or on the platforms. (These materials can either be placed on the platforms or be carried over the platforms. It's alright that the materials don't touch the platforms.)
 - (viii) Materials dropped during delivery will not be deducted from the score.
 - (ix) If the project is successfully completed, 60 points will be awarded. For partial success, 20 points are awarded. Inoperable projects will be received 0 points.
 - (x) Operation time of Specified device: within 3 minutes (elementary school), 4 minutes(junior high school),5 minutes(senior high school) °

	Elementary School	Junior High School	Senior High school
Structural Score	700	900	1100
Operational Score	360	480	600
Total Score	1060	1380	1700
Converted Score	32	32	32

Device scores will be calculated as follows:

- (i) Elementary School teams: When teams receive a structural score of 600 points and an operational score of 240 points the conversion score is:
 $(600 + 240) / 1060 \times 32 = 25.36$ (25.3 when rounded to 1 d.p.)

	<p>(ii) Junior high school teams: When teams receive a structural score of 780 points and an operational score of 420 points the conversion score is:</p> $(780 + 420) / 1380 \times 32 = 27.83 \text{ (27.8 when rounded to 1 d.p.)}$
--	--

7.4.4.3. Specified Device Grades:

The Structural Score applicable for Specified Devices (20 points deducted for each irregularity; 100 points deducted for incomplete tasks.)			
評分向度 Criteria	Elementary School (700 points)	Junior High School (900 points)	Senior High school (1100 points)
Total Score			
1. Preparation Platform			
2. Material Feeder			
3. Conveyor Device			
4. Counting			
5. Static Removal Device			
6. Drying device			
7. Operation Warning Light			
8. Self-regulating Feeder			
9. Material dispenser			
10. Mechanical Arm			
11. Cargo Collection Box			

Operational score of Specified Devices			
Criteria	Elementary School (360 points)	Junior High School (480 points)	Senior High School (600 points)
Total Score			
1. The materials are correctly placed on the preparation platform (up to 60 points, 10 points for each material block).			
2. Feed the materials onto the conveyor, in individually for counting (complete success, 60 points; partial success 20 points; failure, 0).			
3. The counter displays 1-6 numbers in sequence (complete success, 60 points; partial success 20 points; failure, 0).			
4. Materials must be placed in the Static Elimination area (up to 60 points, 10 points for each item).			
5. Drying Device operation (up to 60 points)			
6. Warning light operation (complete success, 60 points; partial success 20 points; failure, 0)			
7. Self-regulating operation (up to 60 points).			
8. Materials placed correctly on the dispenser (up to 60 points, 10 points for each item).			
9. Mechanical arm operation (up to 60 points).			
10. Cargo collection box Colors sorted correctly each earn 10 points. Materials in the correct place, but incorrect color earn 5 points.			

7.4.4.4 Specified Device Relative Positions:

The specified device-related structures need to be set to the right of the work area in the positions shown below.

The specified task area (60cm x 60cm) can be raised up and does not need to be on the table surface, but the Process 1 to 11 must lie in the same plane.

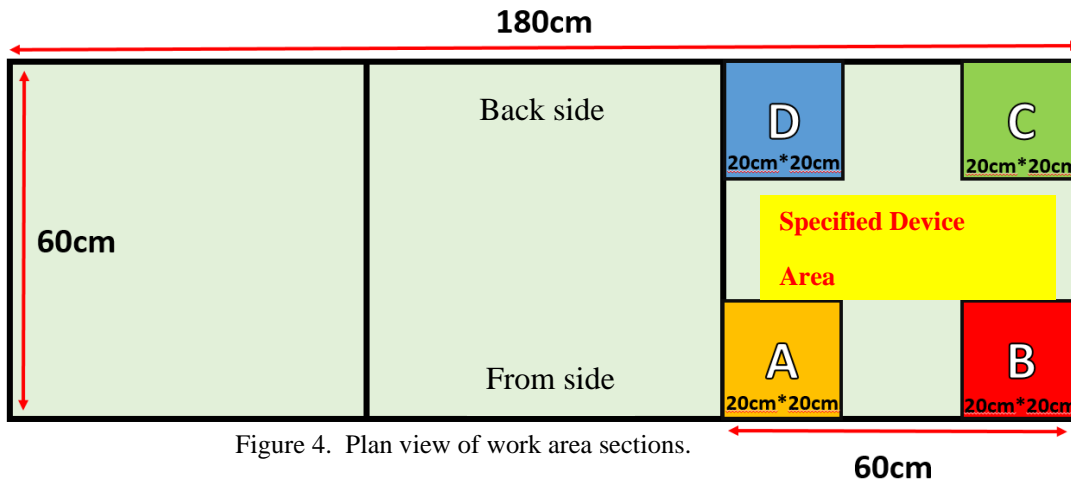
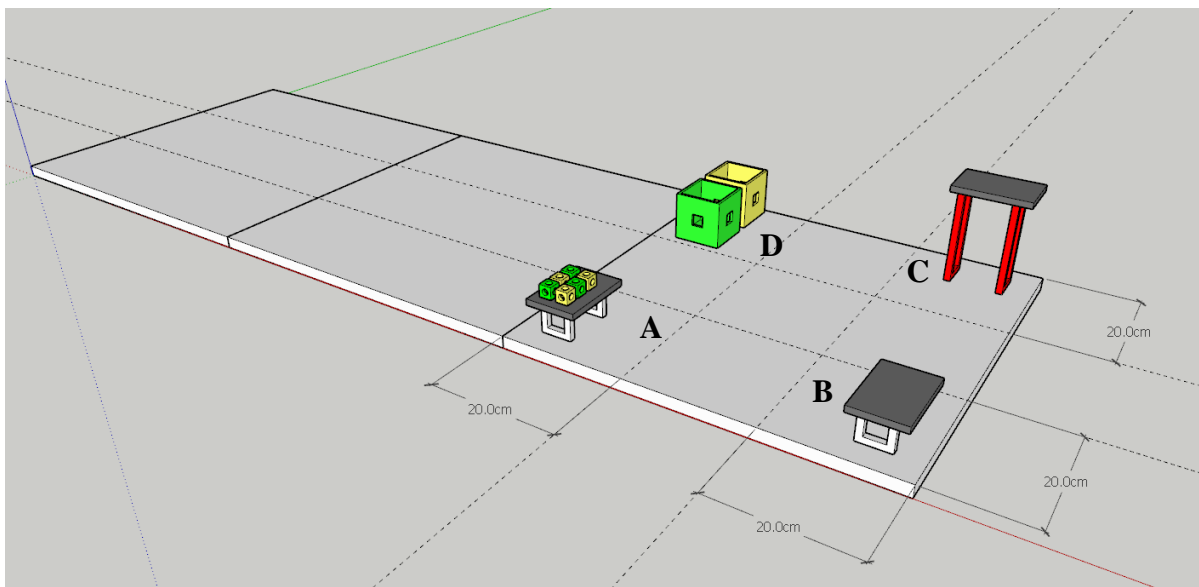

Figure 4. Plan view of work area sections.



7.4.5 Scientific Concepts

Scientific concepts must meet the basic principles and be self-assembled and self-designed. Contestants should be able to understand the principles and contents of their devices and be able to explain the functions to judges.

- (i.) Scoring of scientific concepts occurs after the devices are assembled and have been demonstrated. If a commercially available product or other finished product is used, no scientific concept score will be granted.
- (ii.) 14 scientific concepts are needed, teams must be able to make an adequate explanation to reviewers and judges.
- (iii.) From the Science Principle Concept Table, only 14 concepts can be checked for rating. Contestants should choose the scientific concepts they are most confident with. After the self-assessment form is submitted at around 11 am, no further changes may be made.
- (iv.) Each device needs to contain two scientific concepts for scoring. If there are multiple scientific concepts to choose from, contestants should still check only the scientific concepts that require judgment.
- (v.) There are also five self-rating items on the self-rating form. Players may fill in up to five items according to their design, but may not duplicate the items in the self-evaluation form.

The following are examples of judgments of scientific concepts:

- (i.) Start the light source, the light source illuminates resulting in reflection, refraction, diffraction and other optical phenomena. Teams then receive the optical concept score. If you turn on the power only to turn on the LED light, teams will only receive the electrical score.
- (ii.) The ball rolls down and collides with a bell or other object to produce a regular or irregular sound for an acoustic score. If you turn the power on and the buzzer sounds, teams only receive the electrical score. If you hit a connecting rod to open a commercial music box and produce music, because the music box design is “finished, only the connecting-rod score is valid.

7.4.6 Green Energy Requirements

- (i) The contest's green energy component includes five types of wind, hydro, solar, magnetic and chemical energy. There should be a green energy-driven mechanism in the device area and the successful starting of the next device will earn teams 5 points. In total teams should submit two green energy devices and implement them somewhere between the first device and the Specified device. The energy application for each of the two devices should not be duplicated. The highest score for this category is 10 points.
- (ii) Many green energy applications previously did not meet the standards of the judges and reviewers. The competition aims to emphasize the concept of energy conservation, and so green devices must also be able to start the next device in the chain.
- (iii) Green energy devices may not use batteries.

7.4.7 Green Energy Examples

(iv) Wind energy

Must be started by the previous device. Must also be able to use wind power only, and through operation, be able to start the following device in the chain.

(v) Water energy

Must be started by the previous device. Must also be able to use water power only, and through operation, be able to start the following device in the chain.

Use of drive mechanisms to promote water flow exploiting potential-energy differences or pressure differences is permitted. Hydraulic linkage, buoyancy, are part of the science concepts and not included in the green energy score for water.

(vi) Solar Energy

Must be started by the previous device. Must also be able to use (simulated) solar power only, and through operation, be able to start the following device in the chain.

Simulated solar light source should be shone on to the solar panel. Only lighting the LED light up but being unable to drive the next device will be counted as failure.

Because the current generated by the solar panel is too small to start the motor, the general method is to use a series battery as a backup. At this time, the solar panel is only regarded as the circuit switch operation, and cannot be regarded as the main energy driving mechanism. It will be regarded as the failure of the green energy level.

(vii) Magnetic energy

Must be started by the previous device. Must also be able to use magnetic power only, and through operation, be able to start the following device in the chain.

Magnetic energy can be converted into electrical energy or kinetic energy such as electromagnetic induction. For example, a Gaussian slingshot will accelerate the ball impact, leading to the next mechanism starting. Using only magnetic attraction and repulsion is a science concept, not a Green concept.

(viii) Chemical energy

Must be started by the previous device. Must also be able to use chemical power only, and through operation, be able to start the following device in the chain. Chemical green applications are usually more difficult to configure successfully. For example, the fruit battery required to drive the LED may require at least three or more groups of fruit in series or parallel and it is often insufficient for motors or other mechanical functions. The fruit battery device is only an on-off device, it does not really use chemical energy.

© Rechargeable batteries are not recognized as an application of chemical energy for Green Energy devices.

7.5. Appendix

7.5. .1 Scientific Principles Reference Table

Scientific Principles Reference Table					
Item	Device Number (Contestant Evaluation)	Judge Evaluation	Item	Device Number (Contestant Evaluation)	Judge Evaluation
Law of Inertia			Connecting Rod		
Force & Acceleration (Gravity Potential)			Truss		
Action and Reaction			Chain Gear/ Transmission		
Center of Mass / Domino Effect			Track		
Leverage			Ratchet & Pawl		
Circular Motion& Centripetal Forces			Acoustics		
Pascal's Principle			Electricity		
Communicat ing Vessels			Thermology		

2020 World GreenMech Contest

Bernoulli's Principle			Magnetism		
Wheel and Axle			Elasticity		
Pendulum			Friction		
Static Electricity			Buoyancy		
Worm Screw Worm Gear			Other (to be completed by contestant)		
Capillary Action / Siphon			Other		
Pulley			Other		
Cam			Other		
Gear or Rack			Other		

Note 1: The form cannot be arbitrarily added or modified. Only the scientific principles of self-design can be filled in other parts.

Note 2: Scientific principles and green energy cannot be double-counted. Only 14 scientific c principles can be selected. If you choose more than 14, please delete more.

Note 3: The device number field can only be filled in with one single option. Do not fill in multiple device numbers, otherwise please delete for judge grading.

7.5.2. Device Labels & Green Labels

Contestants must print their own device labels and green energy stickers. The size should be such that all information can be seen clearly, black and white printing is acceptable.

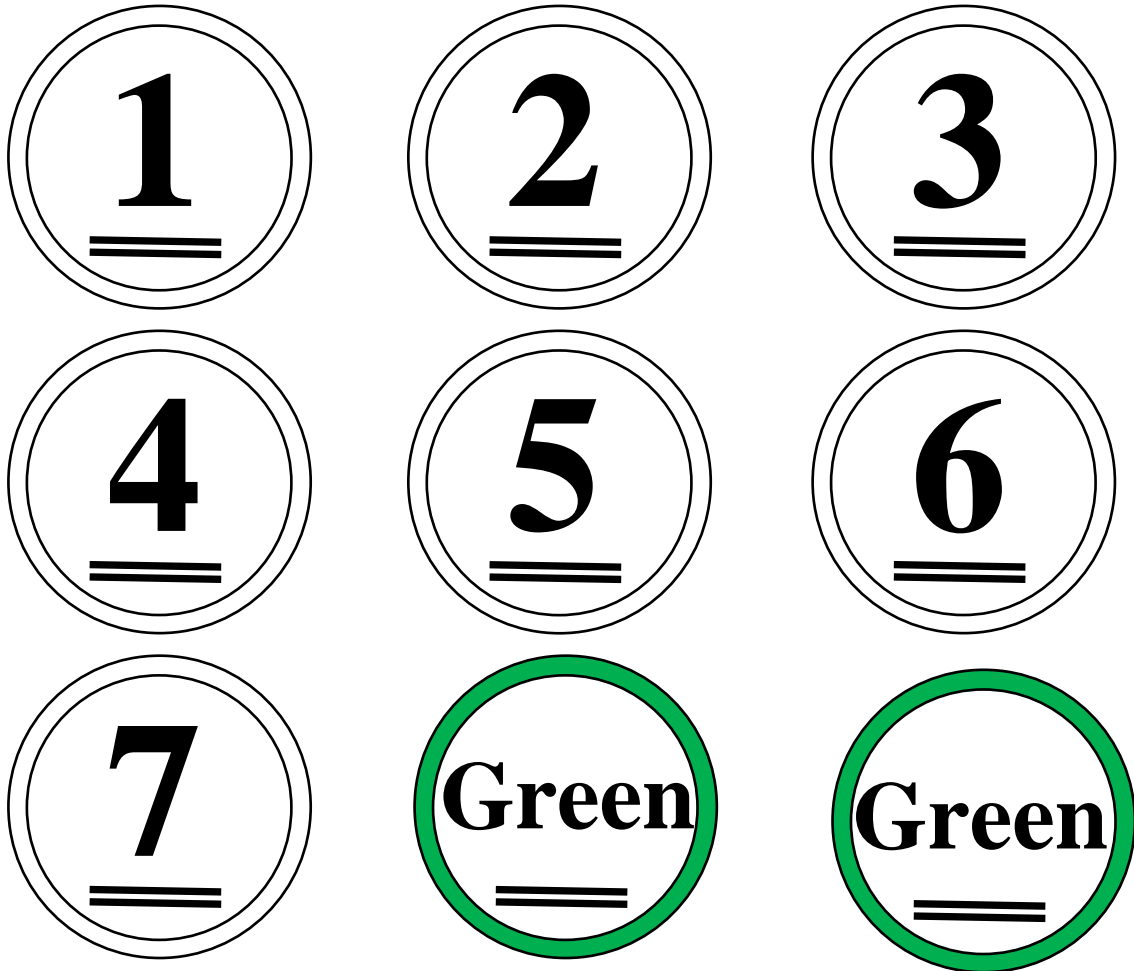

8. Robot for Mission (R4M)

8.1. Contest Theme: Smart Farm

R4M Schedule		
Time	Item	Remarks
07:40 - 08:20	Registration	<ol style="list-style-type: none"> 1. After registration contestants should enter the venue and not leave until the event has concluded. 2. After 08:00, only contestants may be in the competition area. Team leaders and parents/guardians are not permitted after this time.
08:00 - 08:40	Materials Inspection	<ol style="list-style-type: none"> 1. Team leaders shall stay in their assigned areas after 08:00 and shall not enter the competition venue. 2. Judges will carry out a building materials inspection. Blocks may not be assembled in advance. Chains are the only exception to this rule. 3. After passing the materials examination a label will be applied, students should then sit at the table and wait without touching the materials. 4. Personal items like bags can be brought into the venue but must be placed on the table in keeping with the inspection record. 5. Contestants need to submit their Certificate of Student Enrollment, see Section 10.2.
08:40 - 09:00	Clarification of Rules	<ol style="list-style-type: none"> 1. Clarification of the rules and precautions of the competition
09:00 - 09:15	Opening Ceremony	Participants attend the opening ceremony.

09:15 - 11:15	Assembly & Practice Time	
09:40 - 11:30	Work Submission Period	<ol style="list-style-type: none"> 1. Check to confirm the robot does not contain metal parts. 2. The robot and any spare car or other additions shall be weighed. 3. Participating robots (including spares) need to be verified by judges and will be retained until the contest time. 4. 5-Points may be deducted for messy or untidy work areas. 5. For robot size regulations please see Section 8.2.1. 6. After submitting a project, contestants need to clear away all items from the competition area including notebook, blocks, and any unused electronic control equipment.
11:30 - 12:30	Lunch	After lunch contestants are expected to assist with sorting trash and keeping the competition area clean.
12:30 - 12:50	Announcements	When entering the venue, contestants may only carry a notebook, tablet or mobile phone, other items are not permitted.
13:00 - 17 : 00	Competition Time	
17 : 00	Awards Ceremony	Organizers make every effort to finish on time, but some patients may be required depending on announcements and other possible delays.

8. 2. Project Requirements & Restrictions

8.2.1 Size Restrictions

A and B robots must individually not exceed 30×20 cm, the C robot must not exceed 24×20 cm. There is no height limit. Mechanical extensions are excluded from these limits but these must be extended by remote control or servo motor, not manually.

8.2.2 Number of Robots

Teams may only prepare 3 robots. If there are less than 2 robots, the team is considered to have withdrawn from the contest. If the robot needs to be repaired, the contestant must receive permission to intervene from a judge. Repair time is included in competition time, and the process must be re-started from the area specified by the judge. If contestants manually intervene without permission from the judge, the first violation will result in a verbal warning, the second will result in a 5-point deduction. Multiple violations accumulate additional points.

8.2.3 Building Materials

Each team is required to carry any unassembled Gigo blocks. Robot components cannot use metal materials, any uncertified materials brought into the contest may lead to a point penalty or disqualification. Lost, broken, or damaged parts cannot be replaced.

8.2.4 3D Printed Components

For fairness, all robots must be assembled with Gigo blocks. 3D printed, laser cut, CNC parts, PP board pieces are not allowed.

8.2.5 Operation Devices (Smart Phones / Tablets)

Contestants are free to choose their own operation method (e.g. smart phones, tablets, laptops or remote-controllers or related equipment) to operate their robot. Devices should all be prepared ahead of time by the teams, and contestants should remember that there is no electricity available on site. The program version is not limited. In addition to the public Bluetooth remote control provided by the Organizer, contestants may also choose to use infrared remote control. Contestants should remember that because other players may use infrared with the same frequency, interference may occur. Any intentional interference will result in disqualification.

8.2.6 Power Supplies & Restrictions

The contest site does not provide any power. All contestants need to bring their own batteries rated 9V or less for each of the A and B robots. 9V refers to the total voltage across the circuit. All batteries must be marked with their correct voltage. Carbon zinc batteries of 1.5 volts are limited to 6 pieces, 18650 batteries of 3.7 volts are limited to 2 pieces, and square 9-volt batteries are limited to 1 piece.

Robot C uses a micro:bit main control box (1269-W85-A). Voltages must comply with the safety regulations of the main control box, so 6 number 3 (AA) carbon zinc batteries, number 3 alkaline batteries or number 3 rechargeable batteries are permitted. The rated total voltage of a battery must be 5 volts or less. Do not use number 3 lithium ion batteries and “empty” batteries. Batteries must be marked with their correct voltage, covered and insulated correctly; they must not be exposed. Batteries should not cause any pollution or harm due to poor quality or age. If any players are hurt, the team will be disqualified and the team leader will be held responsible. Lead-acid batteries and other large dangerous batteries are strictly prohibited.

8.2.7 Motor Usage Restrictions

Robots A and B may have up to 4 servo motors and C robot may have up to 2 servo motors. The motors and all robots for the competition can only be connected by means of Gigo pieces. It is not possible to connect them with glue, s, foam, double-sided tape or other methods. After the competition, the winners will be asked to disassemble their robots on the spot. If the judges find that a team violates the regulation, this team will be disqualified from winning the prize. And the prize goes to the next team on the score list.

8.2.8 Contest Motor Models

To create a level playing field for all contestants, everyone must use motor models selected from the following parts list. 7328-W85-A1-1,7392-W85-B3, 7392-W85-B1, 7400-W85-A1, 7400-W85-A, 1247-W85-D1-1, 1247-W85-D2, 7447, W85-C, 7412-W85-A, 1247-W85-D3,7447-W85-C1. For more information see please refer to Section 10. 1. If a contestant using the above-mentioned motors installs a different Bluetooth control box; whether it connects a modified motor and the Bluetooth box, or automatically links the motor to other control devices, contestants must confirm that they have complete control over the robot’s functions. If any problems arise during the contest, contestants are required to resolve the problem themselves and ensure completion of the mission.

8.2.9 Material Safety

Dangerous or hazardous materials are strictly prohibited, including but not limited to: fire, corrosive chemicals, dangerous power components, alternate bios, or anything that may potentially cause harm to people. If such items or hazards are brought into the contest site unauthorized, the team will be disqualified.

8.3 Contest Instructions

8.4 Scenario

After a storm, the SMART FARM 2.0 was in disarray. The feed box had been overturned by the strong winds and the animals ran amok making mischief. The lucky rat was running around on top of the charging station, and the piggy was playing hide-and-seek under the pier. The small lucky rat soon sneaked into pig house, and the cows and dogs were strolling about in front of the pier. The giraffes were in their paddock, but leaning hungrily over the fence. The owner of SMART FARM 2.0 had had enough of this mayhem and dispatched three smart vehicles (A, B and C) to deal with the situation. A and B were responsible for returning the overturned feed boxes back to the feed area, bringing the animals back to their homes, taking the giraffes to the feeding area to eat the leaves and bringing the engineers and sapling seeds to the nursery center. The Premium Feed blocks and advanced feed, also had to be transported to the top of the charging station area, seedling area and feed area. Smart vehicle C had to drive to the control station to open the door, find the dragon fruit planting area and harvesting the fruit, before putting the fruit in the correct storage area. Later vehicle C would have to return to the automatic vehicle charging station. If the 3 smart vehicles can do all these things, then the SMART FARM 2.0 should be restored to its former glory in no time!

8.4.1. Site Specifications

The contest arena size is limited to a space not exceeding 180 x150cm and is covered by matte PP photo paper. Each competition venue only accommodates one team. The A, B, and C robots are placed in the departure areas indicated on the smart farm map.



Figure 1. Competition venue image.

8.4.2 R4M Tasks

Positions for the animals, feed, sapling seeds and engineers.



Above: Yellow 2cm squares indicate foot placement for the cow and dog characters.



Above: The cow and dog in their correct positions.



Above: Grey stones show the correct foot placement for piggy.



Above: Piggy in the correct position.



Above: Placement of the premium, advanced feed, sapling seed and engineer items.



Above: 2cm red connectors indicated show the hindfoot placement of the big lucky rat.



Above: Big lucky rat in the correct position.

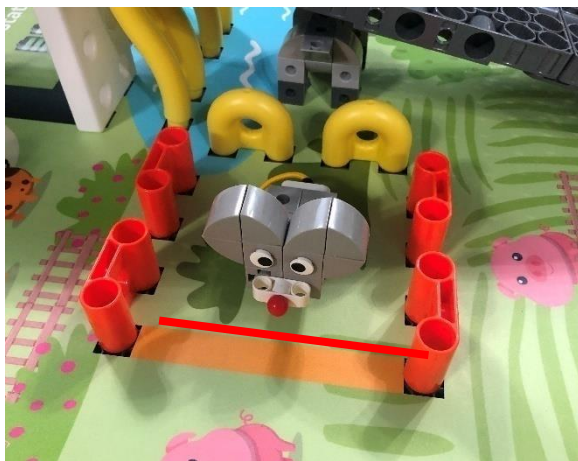

Above: Small lucky rat position. Note, the nose does not pass the red line.



Above: The initial state of the bridge gate.



Above: Yellow 2cm squares show the giraffe initial position.

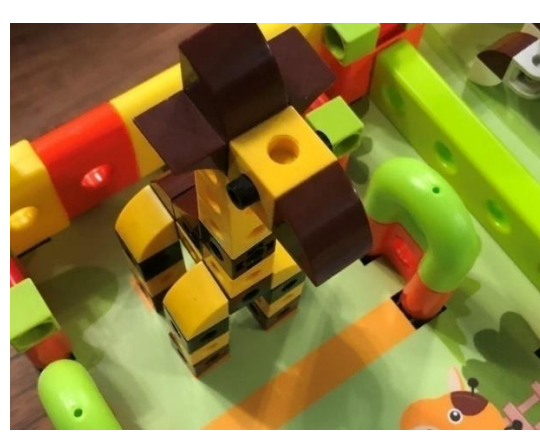

Above: Giraffe in its correct initial position.



Above: Close up image of the initial dragon fruit orchard.



Above: The dragon fruit orchard in relation to the larger game area.





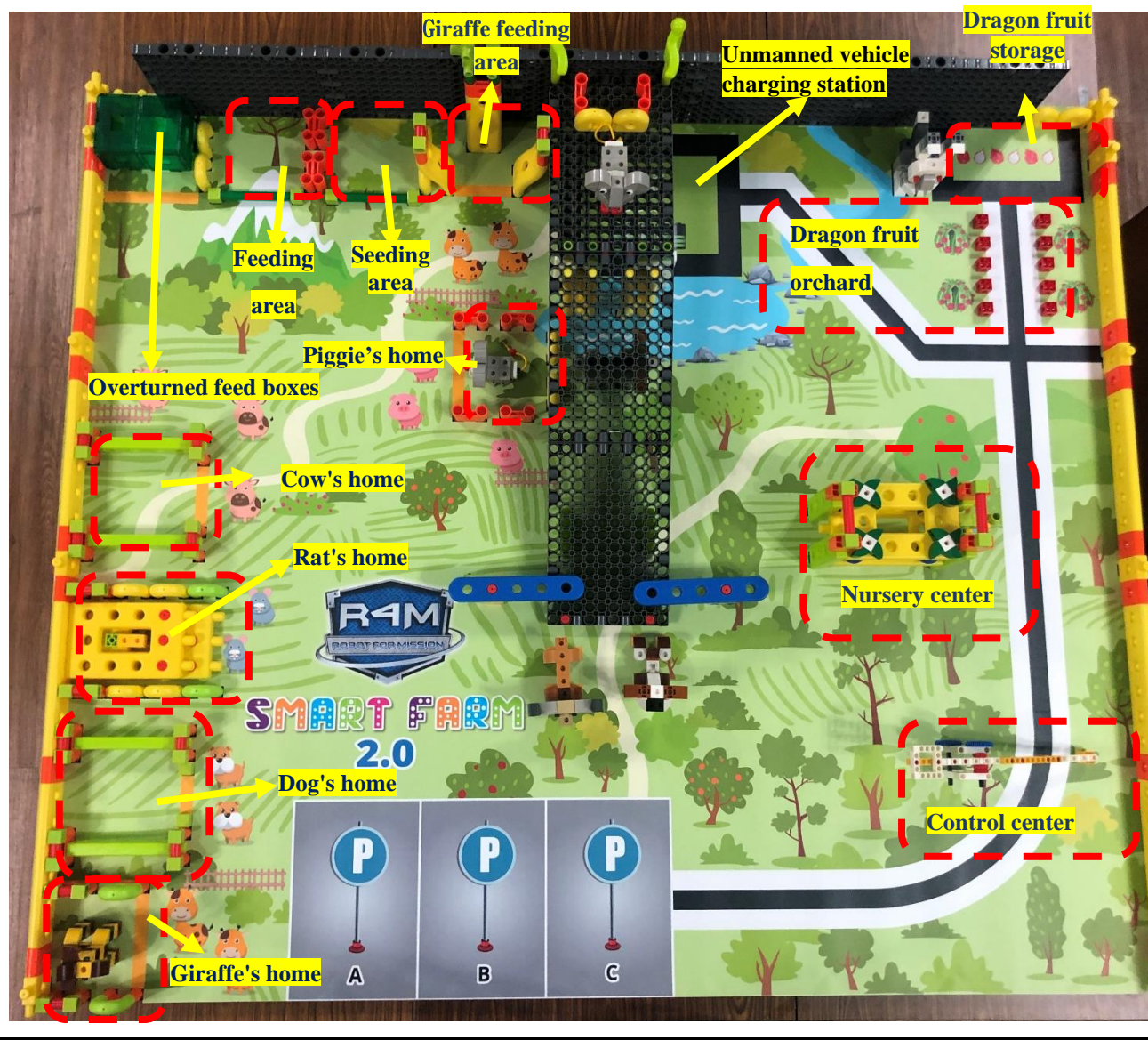

Above: Initial state of the control station.

Partition definition of Smart Farm2.0

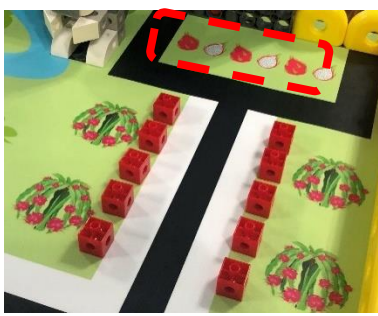
Before the mission, robots A, B and C will be in non-remote-control mode (programmed) and should be placed in the zones marked A, B and C respectively. Contestants may begin after the judge's whistle.

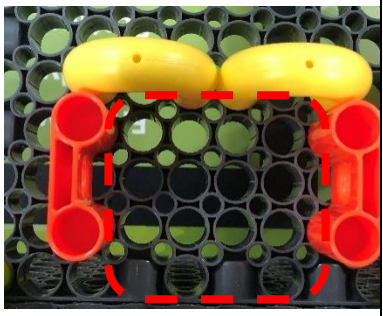

Task Start		
<p>The competition winner is decided using a task/point system. The sum of the team’s points for individual aspects of the tasks becomes the total score of the team.</p>		
<p>Task 1:</p> <p>When robot A successfully leaves zone A, the team is awarded 5 points.</p> <p>When robot B successfully leave zone B, the team is awarded 5 points.</p>		
<p>Task 2:</p> <p>A FORCE SENSOR (1246-W85-C), and a light FOLLOW SENSOR (1247-W5-B3) must be installed on robot C. The relevant specifications are shown in Appendix 10. 1. The program can be written, corrected or uploaded during the contest by contestants. Robot C’s starting mechanism must be initiated by either Robot A or B touching the FORCE SENSOR (1246-W85-C). If robots A or B start robot C, and Robot C successfully and fully leaves the starting area, 5 points are awarded. Robot C follows the black line and collects the 10 dragon fruit items from the dragon fruit orchard, depositing them in the correct storage area to obtain the task points. The scoring table is shown below Note 1. For the elementary school teams, dragon fruit can be collected by robots A or B, and taken to the dragon fruit storage area. Robot C must successfully follow the black line to the unmanned vehicle charging station for charging, where 20 points will be awarded. Entering successfully means that the entire robot is parked within the unmanned vehicle charging station, no part may extend beyond the black line. If the A or B robot sends the engineer to the top of the charging station from the nursery center, 10 points are awarded. If the above four tasks are completed, teams are awarded a total score of 80 points.</p>		
		
<p>The dragon fruit harvest needs to be placed inside the red area indicated.</p>	<p>The dragon fruit harvest has been successfully deposited.</p>	<p>8 dragon fruit have been successfully deposited, 2 have not.</p>

		
<p>As long as the engineer's body is within the red area teams will score. If only the yellow ring is inside, not points are awarded.</p>	<p>A successfully placed engineer.</p>	<p>An unsuccessfully placed engineer.</p>

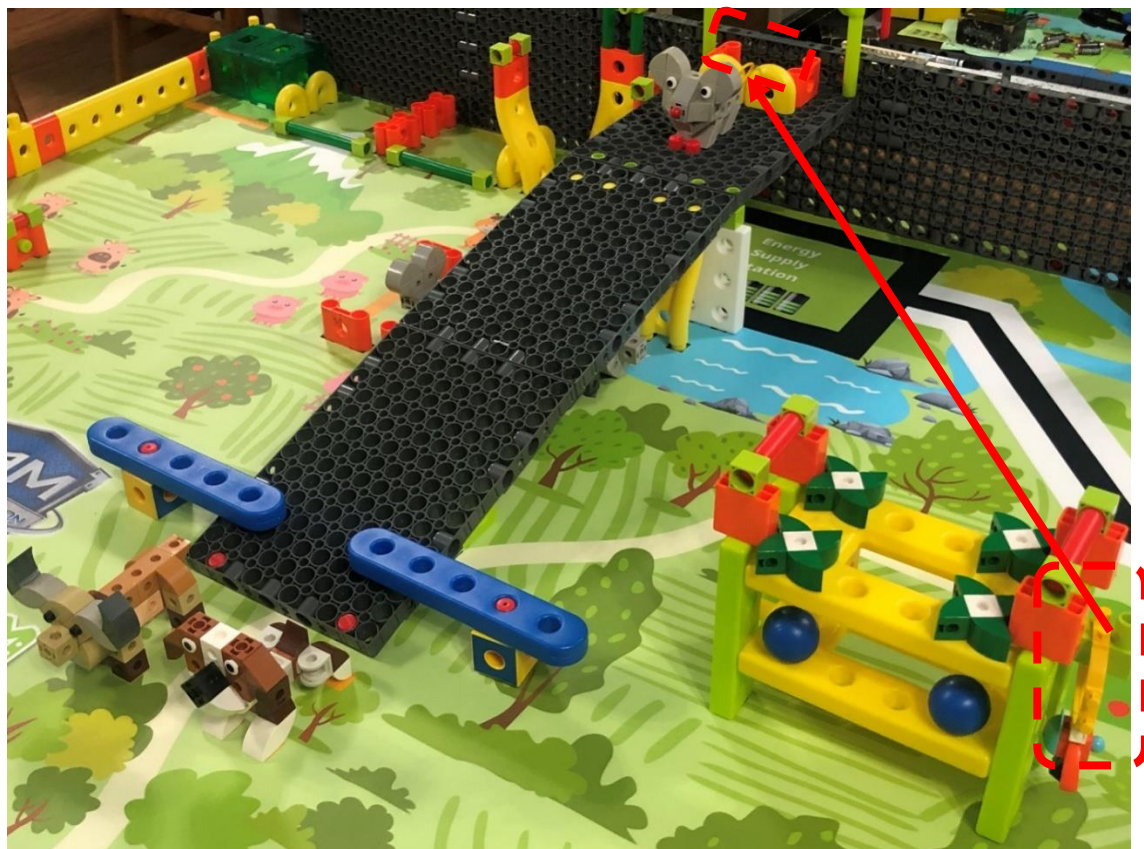

Above: Engineer's final location indicated in red.

Note 1: Dragon fruit score table

Quantity	1	2	3	4	5	6	7	8	9	10
Points	1	2	3	4	6	8	10	12	16	20

Note 2: After Robot C starts, if there is a programming error, contestants can make corrections in

programming or modification, however, this time is counted as competition time.

Note 3: Robot C uses micro:bit software and the Gigo micro:bit control box (1269-W85-A). See Appendix 10. 1. for more information.

Note 4: At departure Robot C's head must face forward (toward the bridge) and not directly to the black line.

Note 5: Robots A, B, and C must be assembled by the contestants themselves. Robot C uses a programming device (notebook, tablet and cable) and the micro:bit program. If contestants need to connect to the internet, they must prepare for this themselves.

Note 6: For the junior high school and senior high school teams, Robot C must complete the dragon fruit storage task and unmanned vehicle charging station task in the same program cycle to score. If completed in stages, only the dragon fruit storage area task will be counted.

Note 7: For the junior high school and senior high school teams, if Robot A or B moves the dragon fruits in the planting area, this is counted as site destruction and carries a 5-point penalty. The number of deductions is additional up to 10 counts.

Note 8: When robot C enters the black line of the unmanned vehicle charging station, robot C must drive itself using self-tracking to enter the area and score only if robot C completely stops in the area without touching the black line. If robot A or B pushes the C robot into the black line of the charging station, no score is obtained.

Note 9: If needed, robot C has three repair opportunities in the R4M World Contest. Regional competitions may make unlimited repairs.

Task 3:

Either robot A or B must send the pigs, big lucky big rats, and little lucky rats to their correct places to earn points. Each animal in its correct place earns 25 points, for a total possible score of 90 points. If retrieved lost animals remain standing, teams score 25 points per animal, 50 points for two animals, and 90 points for all three. If retrieved animals fall over teams score 15 points per animal, 30 points for two animals, and 45 points for all three.

Note 1: Robot A and B must use the Gigo control box. Regional and country competitions are not limited in this way.

Note 2: Animals must pass the yellow line completely. No part of the animals may extend beyond the yellow line. If any part of the feed is on the yellow line it will not score.

Note 3: For elementary schools, there are no obstacles under the bridge.

Note 4: The tail parts of the big lucky rat and small lucky rat (yellow line and red ball) are allowed to exceed the range of 3 x 4 FRAME.

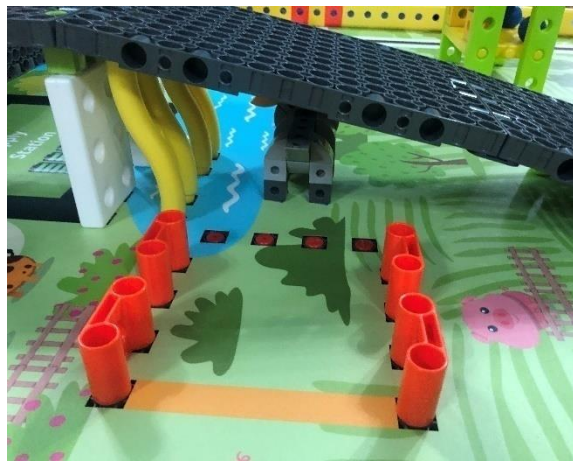

Above: Elementary level pig house location.



Above: Junior and senior high-level pig house location. Note: yellow barrier at the back.

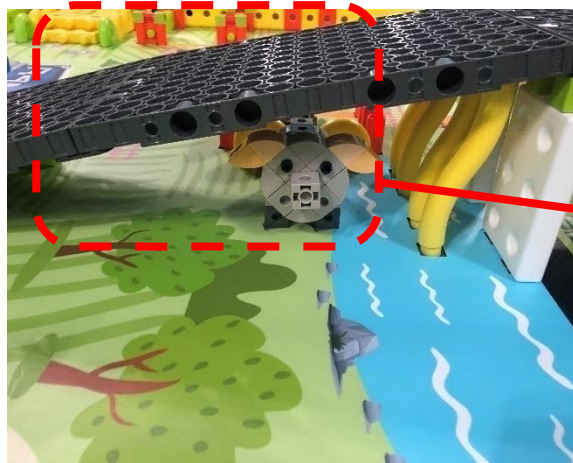

Above: Peggie playing hide-n-seek under the bridge.

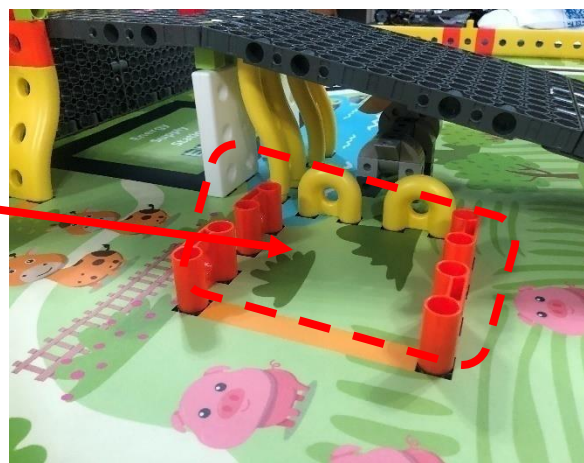

Above: Pig home.

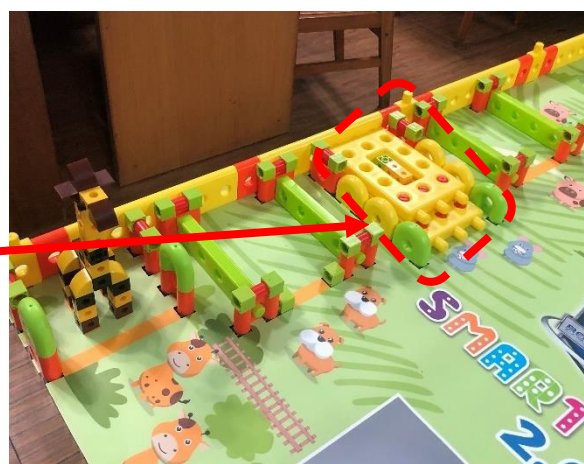
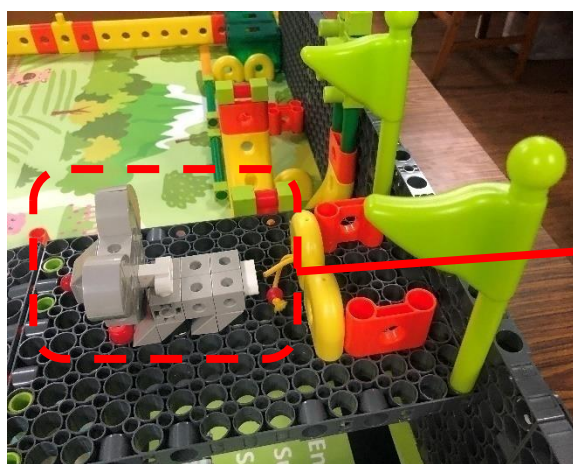

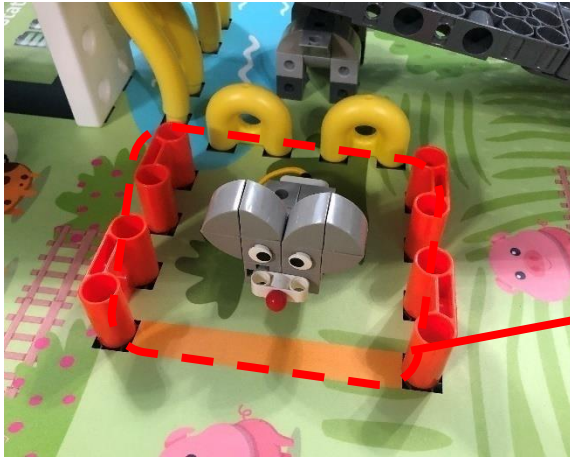
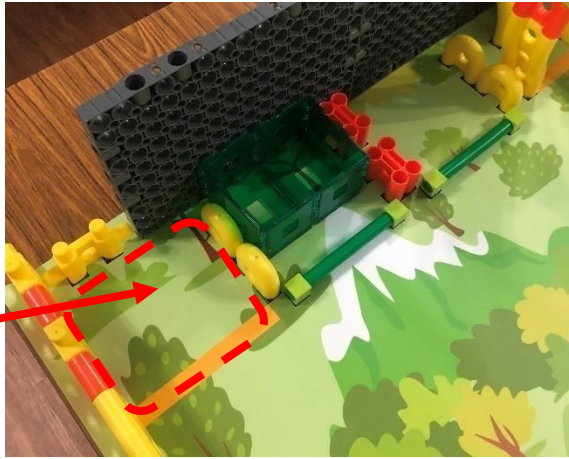
<p>Above: Big lucky rat starting position.</p>	<p>Above: Big lucky rat final location, whole animal should be within the red marked area.</p>
	
<p>Above: Small lucky rat hiding in pig house.</p>	<p>Above: Small lucky rat's final destination, while animal should be within red marked area.</p>

Task 4

The three animals must be transported to the designated areas by robots A or B.

If the cow is put completely in the designated resting area and remains standing, teams score 10 points.

If the dog is put completely in the designated resting area and remain standing, teams will score 20 points.

If the giraffe is put completely in the designated area and remains standing, teams will score 25 points.

If the cow is put completely in the designated resting area and falls over, teams score 5 points.

If the dog is put completely in the designated resting area and falls over, teams score 10 points.

If the giraffe is put completely in the designated resting area and falls over, teams score 15 points.

If all three animals are put completely in the designated resting areas and remain standing, teams score 70 points total.

Note 1: Animals must be completely within the yellow line; no part of the animal may extend past the yellow line. If any part of the animal is on the yellow line it will not score points.

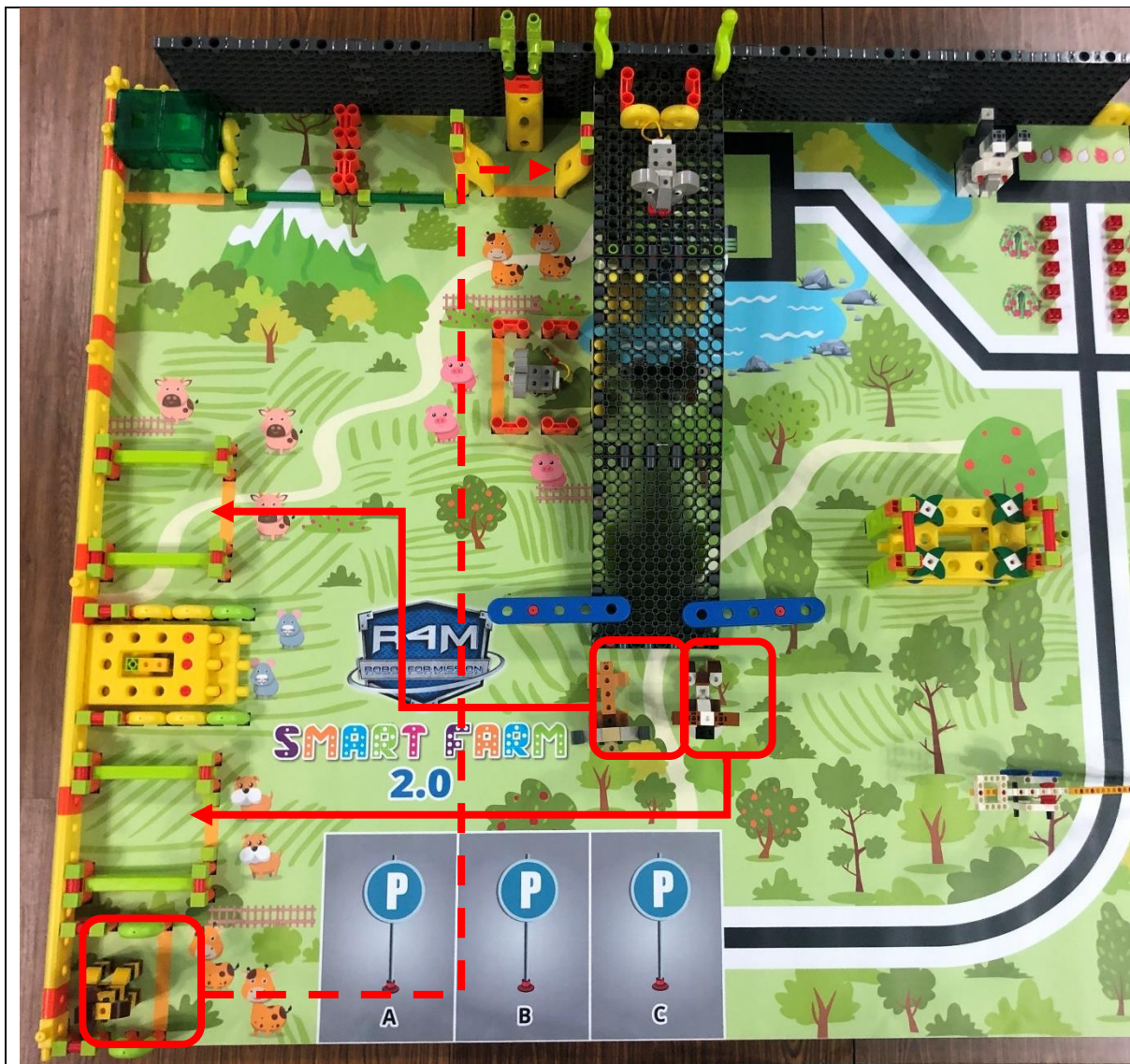

Task 5





Robot A or B must take the feed into the left and right feed areas in the lower playground zone to score. The scoring table is shown below:

Zone	Quantity	Score			
	Score	One Piece	Two Pieces	Three Pieces	Four Pieces
Box upright in feed area, premium feed inside	8	20			
Box not upright in feed area, premium feed inside	4	10			

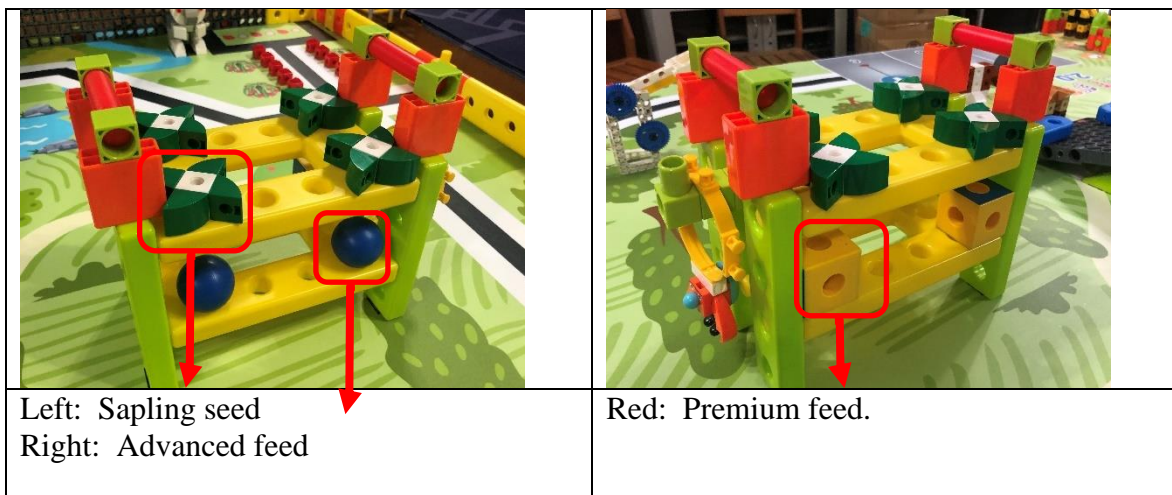
Box upright in feed area, advanced feed inside	6	16		
Box not upright in feed area, advanced feed inside	3	8		
Send the sapling seeds to the seedling area	4	11	18	25

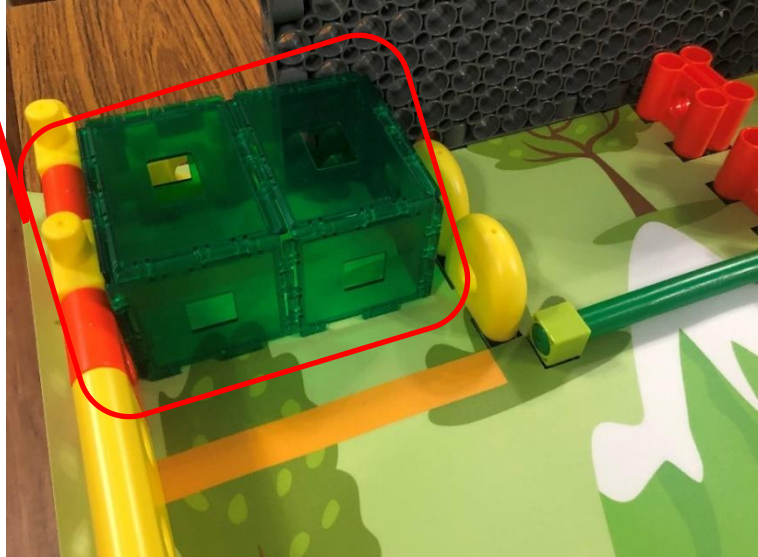
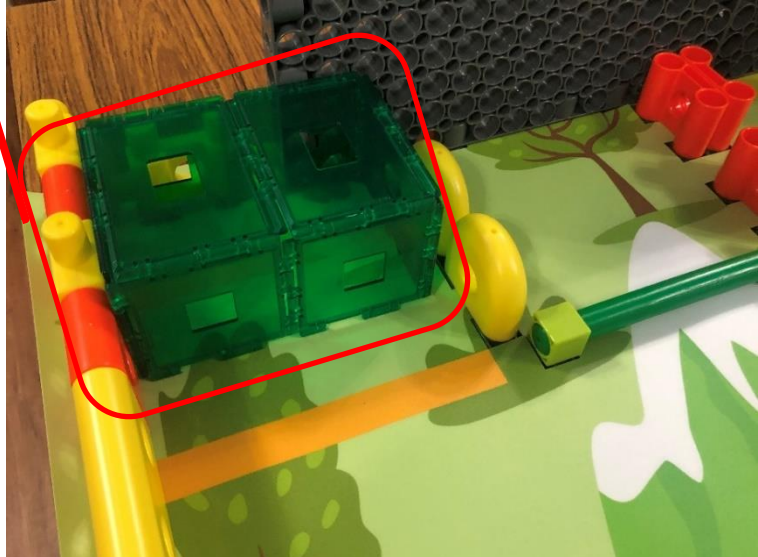
- (1) If robot A or B moves the green feeding box to the feeding area and keeps the box the right way up, and puts the premium feed into the feeding box, teams score 8 points for one piece, and 20 points for two.
- (2) If robot A or B moves the green feeding box to the feeding area and doesn't keep the box face up and puts the premium feed into the feeding box, teams score 4 points for one piece, 10 points for two.
- (3) If robot A or B moves the green feeding box to the feeding area and keeps the box face up and puts the advanced feed into the feeding box, teams score 6 points for one piece, and 16 points for two.
- (4) If robot A or B moves the green feeding box to the feeding area and doesn't keep the box face up and puts the advanced feed into the feeding box, teams score 3 points for one piece, and 8 points for two.
- (5) If robot A or B moves the sapling seeds to the seedling area, teams score 4 points, for each additional feed unit, teams receive an extra 7 points. If all 4 feed units are successfully transported, teams score 25 points.
- (6) If robot A or B keeps the feeding box face up, places it in the correct area, and completes all the tasks above (1), (3), (5), teams score 90 points.



<p>Overtured feed box.</p> 		
		
<p>Robot A or B moves the green feeding box to the feeding area and keeps the box face up, 10 points.</p>	<p>Robot A or B moves all the sapling seeds to the seedling area, 25 points.</p>	<p>Robot A or B moves the green feeding box to the feeding area and keeps the box face up and puts all the premium and advanced feeds into the feed box, 36 points.</p>
		
<p>Robot A or B moves the green feed box to the feeding area and doesn't keep the box face up, and puts all the premium and advanced feed into the feeding box, 18 points.</p>		

8. 5. Scoring Criteria

8.5.1 3 minutes are given to complete the task, the highest scoring team wins.

8.5.2 The total weight of the robot also affects the score; lower weight robots receive higher scores.

8.5.3 Scoring Sequence

Awards will be based on scores. In the event that teams have the same score, the final result will be determined by the following order of decisions.

Sequence order	Sequence item
1	The number of tasks completed.
2	The number of tasks with a full score.
3	Score of task two
4	Score of task five.
5	Score of task three.
6	Score of task four
7	Score of task one.
8	Total weight.

8.5.4 Competition Time

The total time of the contest is 3 minutes. After 3 minutes, contestants are not allowed to continue.

8.5.5 Damage to the Contest Area

Any damage to the contest site during the mission will result in a 5-point deduction. This contains damage to all props and animals in the testing area. For junior and senior high school teams this includes disturbing the dragon fruit orchard with either robot A or B (robot C is acceptable).

8.5.6 Competition Order:

Before the competition begins, teams should proceed to their designated area as specified by the map provided by the Organizer.

8.5.7 Work Submission

Teams that have finished their rounds must return their robots to the work display area until the end of the contest.

8.6. Contest Site Rules

8.6.1 Checking Items

After registration, contestants should enter the contest site directly. Toolboxes, personal bags, use of tools (including ornament props), and other potentially dangerous objects will be actively checked on site. If any signs of fraud or cheating are discovered, the team will be disqualified.

8.6.2 Assembly Time:

The assembly time, including practice time, is 2 hours.

8.6.3 Missions

Contesting teams build their robots on site during the contest. After building, teams must follow the contest schedule to undertake the missions. No assembled components are allowed into the contest site. Violators of this rule will be disqualified.

8.6.4 Allowance for Practice

During assembly time, some limited opportunities for practice may arise. As practice spaces are limited, please follow the instructions of the staff regarding these opportunities.

8.6.5 Access Restrictions.

During the contest, team leaders or parents are not allowed to enter the contest area or pass anything to the contestants. Any violations will result in a 5-point deduction from the team score.

8.6.6 Interference with Others

During the contest, no person or team is allowed to disturb the work of other persons, teams or the judges in any way. This includes running around or making loud noises. If this rule is violated and a warning has already been given, violators will suffer a 5-point deduction.

8.6.7 Communications & Communication Devices

Contestants are not allowed to talk, communicate or text non-contestants (eg, team leaders, parents). Violators of this rule will be disqualified. In an emergency situation, contestants should seek help from the Service Center.

Note: Contestants may bring mobile phones, tablets and laptops as controllers, however, to avoid any unwarranted or unjustified punishment, such devices should be on airplane mode or have the SIM card removed.

8.6.8 Private Property

Any deliberate destruction, theft, robbery or attempts to cheat other people of their possessions will lead to a 5-point deduction and probably more serious measures.

8.6.9 Portable Data:

Contestants may bring writing, pictures, video files and other printed data.

8.6.10 Video Recording

To avoid post-match disputes, each team shall record its performance during the competition as evidence of its performance.

8.6.11 Motor Inspection

Winning teams must accept a motor inspection, if the motor does not meet the specifications in Section 10. 1. “ Race Motor Model List”, the team’s award will be withdrawn and the next team in line will be promoted

9. GreenMech Junior Contest

9. 1. Theme: Competition One: Inertia Flywheel 2.0, Competition Two: Sharpshooter

9. 2. Event Schedule

GreenMech Junior Schedule		
Time	Item	Remarks
08:40 – 09:00 (20 mins)	Registration and Materials Inspection	<ol style="list-style-type: none"> 1. Contestants should refer to the team location map on the official website before the contest begins, so they can go directly to their team table and report on the day of the contest. 2. Contestants should check the provided materials against the list they are given. If there is any part missing, the staff must be informed before the contest begins. Once the production time begins, materials cannot be replenished or replaced. 3. Contestants need to present their Certificate of Student Enrollment at this time, please see 10.2 in the full rule book for more information.
09 : 00-09 : 15 (15 mins)	Opening ceremony, rules reminder, lot drawing for scoring area	
09 : 15- 09 : 45 (30 mins)	Competition One: Inertia Flywheel 2.0 Assembly & Practice Time	<ol style="list-style-type: none"> 1. Contestants can only use materials provided by the organizer on site, please see 9.3 in the full rule book for more information. 2. Models produced for the competition are built and tested at the same time.
09 : 45- 10 : 25 (20 mins)	Competition One: Inertia Flywheel 2.0 Competition Time	<ol style="list-style-type: none"> 1. During the competition, contestants may only use the provided peg remover. Other outside tools are not permitted.

		2. Models will be weighed before the competition begins.
10 : 25-10 : 45 (20 mins)	Competition Two: Sharpshooter Assembly & Practice Time	1. Contestants can only use materials provided by the organizer on site, please see 9.3 in the full rule book for more information. 2. Parts and pieces for models will be reused. The model used for the first competition will need to be disassembled for the second contest.
10 : 45-11 : 15 (10 mins)	Competition Two: Sharpshooter Assembly & Practice Time	1. During the competition, contestants may only use the provided peg removal tool. Other outside tools are not permitted. 2. Models will be weighed before the competition.
11 : 15-11 : 40 (25 mins)	Site Recovery	
11 : 40-11 : 50 (10 mins)	Parents, teachers may enter venue	
11 : 50-12 : 20 (30 mins)	Awards Ceremony	Awards will be given after the results are settled.

9.2.1 **If a team fails to enter the venue at or before the designated check-in time, due to any force majeure factor, they may still join the competition, however, no time extension or regulation change will be granted. They may only participate in the remaining unspent time.**

9.3. Contest Objectives

9.3.1 Material Specifications:

Contest equipment is standardized for all groups and includes 1 set of Gigo #1261 Scientific Tour (excluding instructions) and 30 rubber bands. Do not prepare or bring other materials or tools (including blocks). Teams violating this rule will be disqualified.

9. 4. Contest Method

9.4.1 Contest One: Inertia Flywheel 2.0 【 Contestants can refer to the Gigo#1261 Flywheel Model 】

a. Production Restrictions:

(1) Each team produces a car with a flywheel device. A flywheel is a device used to store rotational kinetic energy. An external force acts on the wheel and when that external force stops, the wheel will continue to move.

(2) The size of the car body is not limited, but it must fit completely within the preparation area (80cm x 60cm) and should not exceed the range of the preparation area before starting.

(3) The C-40T scoring gear can be placed anywhere on the car body (as shown in Figure1.). If the scoring gear is not attached, the contestant will not receive a score. If there are multiple C-40T gears on the car, the team should explain to the judge which one is the designated scoring gear before the contest.

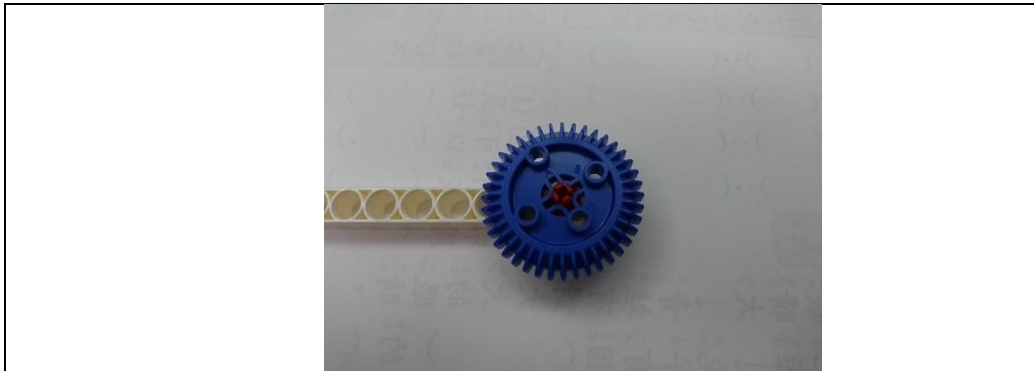

Figure 1. Scoring gear for use on the Flywheel car.

b. Contest Rules:

(1) This competition will use the racing car site (see Figure 9.4.1.-2) that has a gantry at the red line. The gantry is approximately 20 cm away from the target area, and there are three extra scoring areas, A, B and C on the gantry.

(2) The competition area is as shown below, all units are in CM. At the beginning of the production time, the scores for each target area will be announced (1 zone will be worth 10 points, 2 zones will be worth 5 points, 2 zones will be worth 3 points. Non-target areas will be worth 0 points. A, B, C are three boards, striking one will score two extra points, teams may only choose to strike one board for the extra points.

Striking two or three boards grants no bonus over the initial 2-point bonus for striking

one.

- (3) The flywheel car will be operated by one team member and prepared in the preparation area or near the race site. Each team has three opportunities to score. The target area in which the scoring gear is last stopped marks the Zone the car is in. If the scoring gear spans two scoring areas, the higher score area is taken to be correct. If the flywheel car hits an extra board, the rule (3) above applies.
- (4) The car body must be leaving the contestant's hand before the front of the car passes the start line (shown by the arrow on Figure 9.4.1.-2). The first violation of this rule is given a warning and contestants may make a second attempt; a second violation will get score 0 points.
- (5) If contestants find that the car body is faulty after commencement, the judge will allow up to 20 seconds for repair. Repairs can only be made in the preparation area or around the race site.
- (6) The gantry placement is shown in Figure 9.4.1.-4 and Figure 9.4.1.-5. It will not be fixed to the ground. Contestants must check the site and the gantry for problems before the first operation opportunity. After that, if there is a problem caused by the contestant's operation or if the gantry becomes skewed, it will not be adjusted, repaired or reset.
- (7) During the pre-competition period, while weighing and attempting the race, no part of the car body can be changed.
- (8) The site is prepared by the organizers in large format printing on water-based pp photographic paper. This will be secured on the ground.



Figure 9.4.1.-2: Race map (300cm x 140cm), strong red line indicates gantry placement.

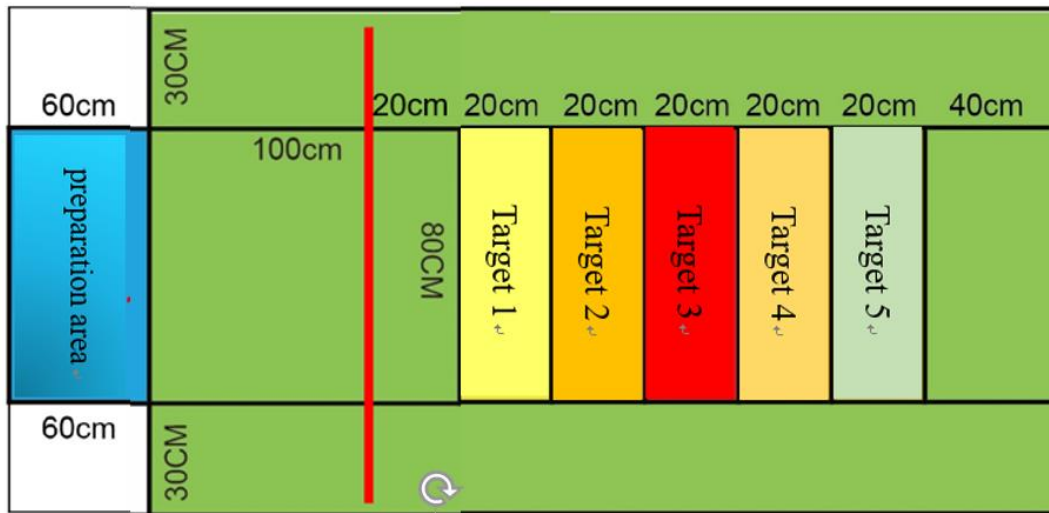

Figure 9.4.1.-3. Dimensions and target areas in relation to preparation area.



Figure 9.4.1.-4 Gantry front view.



Figure 9.4.1.-5. Top down view of right-hand gantry arm.

9.4.2 Contest two: Sharpshooter 【Contestants can refer to the Gigo#1261 Rubber Band Gun Model.】

a. Production Restrictions:

- (1) Each team makes a pistol. The form and quantity of the pistol(s) are not limited; however, only one projectile (rubber band) can be filled at a time.
- (2) 30 rubber bands are provided by the Organizers (10:25~10:45). Additional rubber bands will be provided for practice, but the original 30 rubber bands should be retained by the teams and will not be distributed during the competition.

b. Contest Rules:

- (1) Each team sends one person as a shooter and one as gunner's mate, to collect/reclaim the projectile. The shooter is required to stand at the starting line (marked by an arrow in Fig. 9.4.2.-1), the gunner's mate should stay nearby to assist in loading projectiles. A table can be used to hold the gun and rubber bands, contestants can adjust the table to suit their situation. Shooters may not lean on the table.
- (2) One minute of competition time is allowed for the contest, this includes loading and reloading. If the contestant finds a problem with the gun before the contest begins, they will have 20 seconds to resolve the issue. Any repairs must be completed with just one wrench and within the preparation area. The target score areas are shown in Figure 9.4.2.-2 (5 points for small jars, 5 jars in total, 3 points for large jars, 3 jars in total).
- (3) During the contest, the shooter shall not pass the preparation line. Violation of this rule for the first time will result in a warning, the second violation will result in disqualification. If the gunner's mate fires the gun the team is disqualified and score 0.
- (4) If all the targets have been knocked down within one minute, the time taken will be used to determine the contest winner. In such a case, the shortest time taken will be the winner. Targets are regarded as knocked down when the side of the jar is lying completely on the supporting platform.
- (5) When weighing before competition, all the guns being used must be weighed.
- (6) It is recommended to bring your own goggles. Players must be responsible for their own safety. If the safety of other teams is affected, the referee has the right to disqualify the team.

c. Target icon and description

- (1) The target area of the competition will be placed on a long table behind the race site

from the first competition. Target jars will be placed in the center of the race site. The height of the long table will be decided by the organizer on the day.

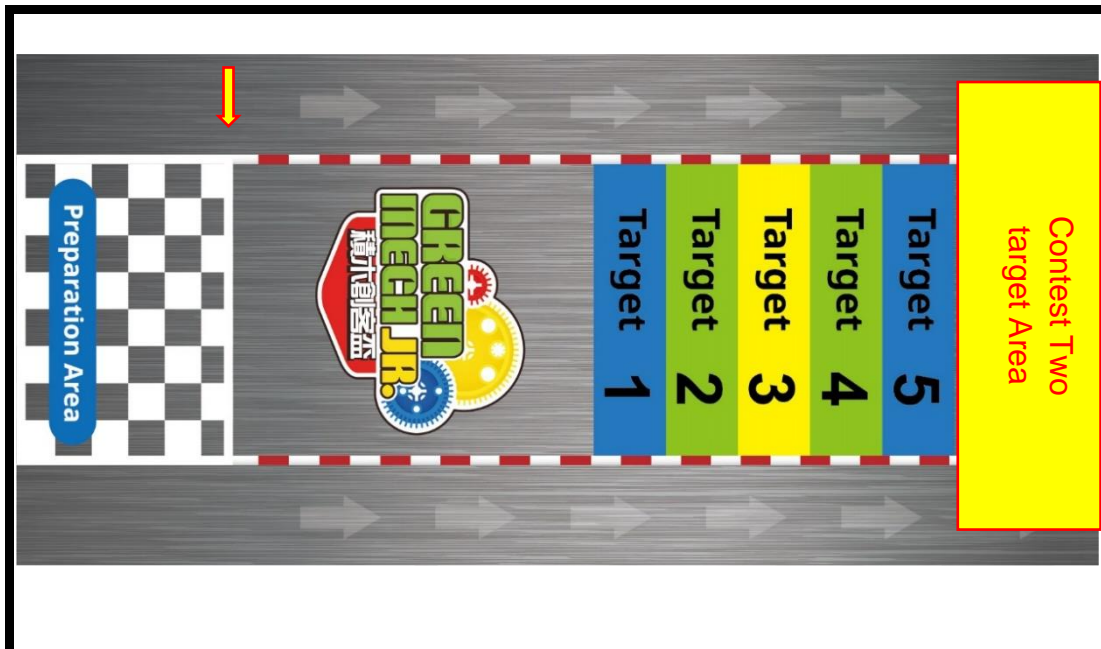

Figure 9.4.2.-1 Diagram of contest area.



Figure 9.4.2.-2 Image of target area



Figure 9.4.2.-3 Image of small bottle, approximately 8.5 cm in height, with a mouth 4.5cm in diameter, weight 7 grams.



Figure 9.4.2.-4 Image of small bottle, approximately 10.8 cm in height, with a mouth 5.2 cm in diameter, weight 10 grams.

9. 5. Criteria

9.5.1 This competition adopts a point based ranking system. If two teams' point scores are the same, the rankings will be arranged according to the following table.



Sequence order	Sequence item
1	Score of two tasks
2	Score of task two.
3	Time of task two.
4	Score of task one.
4	Total weight of two tasks. lower weight device is the winner

10. Appendix & Forms

10. 1. List of Race Contest Motor Models

2020 World Robot for Mission Contest R4M Competition Motor Model List

1		C-30X MOTOR WITH WIRE CONNECTOR	7328-W85-A1-1
2		C-32X PLANETARY GEARBOX(DDM)	7392-W85-B3
		C-CAR MOTOR	7392-W85-B1
3		C-40X MOTOR WITH WIRE CONNECTOR (DDM)	7400-W85-A1
		C-40X MOTOR WITH WIRE CONNECTOR	7400-W85-A
4		C-180° SERVO MOTOR	1247-W85-D1-1

5		C-CONTINUOUS ROTATION SERVO MOTOR	1247-W85-D2
6		C-50X PLANETARY GEARBOX	7447-W85-C
7		C-50X PLANETARY GEARBOX (DDM)	7412-W85-A
8		C-180 SERVO MOTOR (METAL GEAR)	1247-W85-D3
9		C-LINE FOLLOWER SENSOR	1247-W85-B3
10		C-FORCE SENSOR	1246-W85-C

11	 A blue micro:bit board housed in a clear plastic case. The board features a USB-C port, a micro:bit logo, and several circular ports. The case is open, showing the internal components.	C-Gigo micro:bit CONTROL BOX	1269-W85-A
12	 A white, cylindrical planetary gearbox with a red coiled cable attached to its side. The gearbox has a yellow output shaft and a white connector.	C-50X PLANETARY GEARBOX II(New)	7447-W85-C1

10.2 Student Enrollment Certificate

2020 World GreenMech World Cup - Certificate of Student Enrollment

Team Name				
Contest		<input type="checkbox"/> GreenMech <input type="checkbox"/> R4M <input type="checkbox"/> GreenMech Junior		
Category		<input type="checkbox"/> Elementary School <input type="checkbox"/> Junior High School <input type="checkbox"/> High School		
Photo	Clear photo of the face.	Clear photo of the face.	Clear photo of the face.	Clear photo of the face.
Student Name				
School & Grade				
Date of Birth:				

I certify that the above students are still studying in our school and that the above information is correct.

Signed: _____

Director of Academic Affairs: _____

Principal: _____

Date: _____ (dd/mm/yyyy)

10.3 Complaint Form

2020 World GreenMech World Cup- Complaint Mediation Form

Plaintive Team	
Plaintiff	
Complaint Details	
Case Officer	
Resolution	
Plaintiff Signature	

Notes:

Those who have not filled out this appeal will not be accepted; the overseas team and the GreenMech Junior teams may be sent by Organizers to file the complaint; however, they must still sign it personally to confirm that the details of the complaint are correct.

After the judge has made understood the situation and made a ruling, they must complete the section marked “Resolution” and explain the remaining process to the plaintiff.

If the plaintiff is still dissatisfied with the result of the treatment and refuses to sign, the judge may add a “refusal” in the “Plaintiff Signature” field.